



nRF51802

Multiprotocol *Bluetooth*[®] low energy/2.4 GHz RF System on Chip

Product Specification v1.2

Key Features

- 2.4 GHz transceiver
 - -91 dBm sensitivity in *Bluetooth*[®] low energy mode
 - 250 kbps, 1 Mbps, 2 Mbps supported data rates
 - TX Power -20 to +4 dBm in 4 dB steps
 - TX Power -35 dBm Whisper mode
 - 13 mA peak RX, 10.5 mA peak TX (0 dBm)
 - 10 mA peak RX, 8 mA peak TX (0 dBm) with DC/DC
 - RSSI (1 dB resolution)
- ARM[®] Cortex[™]-M0 32 bit processor
 - 275 μ A/MHz running from flash memory
 - 150 μ A/MHz running from RAM
 - Serial Wire Debug (SWD)
- S100 series SoftDevice ready
- Memory
 - 256 kB embedded flash program memory
 - 16 kB RAM
- On-air compatibility with nRF24L series
- Flexible Power Management
 - Supply voltage range 1.8 V to 3.6 V
 - 7.7 μ s wake-up using 16 MHz RCOSC
 - 0.6 μ A at 3 V OFF mode
 - 1.2 μ A at 3 V in OFF mode + 1 region RAM retention
 - 3 μ A at 3 V ON mode, all blocks IDLE
- 8/9/10 bit ADC - 8 configurable channels
- 31 General Purpose I/O Pins
- One 32 bit and two 16 bit timers with counter mode
- SPI Master/Slave
- Low power comparator
- Temperature sensor
- Two-wire Master (I2C compatible)
- UART (CTS/RTS)
- CPU independent Programmable Peripheral Interconnect (PPI)
- Quadrature Decoder (QDEC)
- AES HW encryption
- Real Timer Counter (RTC)
- Package variants:
 - QFN48 package, 6 x 6 mm
 - QFN32 package, 5 x 5 mm

Applications

- Computer peripherals and I/O devices
 - Mouse
 - Keyboard
 - Multi-touch trackpad
- Interactive entertainment devices
 - Remote control
 - Gaming controller
- Beacons
- Personal Area Networks
 - Health/fitness sensor and monitor devices
 - Medical devices
 - Key-fobs + wrist watches
- Remote control toys

Liability disclaimer

Nordic Semiconductor ASA reserves the right to make changes without further notice to the product to improve reliability, function or design. Nordic Semiconductor ASA does not assume any liability arising out of the application or use of any product or circuits described herein.

Life support applications

Nordic Semiconductor's products are not designed for use in life support appliances, devices, or systems where malfunction of these products can reasonably be expected to result in personal injury. Nordic Semiconductor ASA customers using or selling these products for use in such applications do so at their own risk and agree to fully indemnify Nordic Semiconductor ASA for any damages resulting from such improper use or sale.

Contact details

For your nearest distributor, please visit www.nordicsemi.com.

Information regarding product updates, downloads, and technical support can be accessed through your My Page account on our home page.

Main office: Otto Niensens veg 12
7052 Trondheim
Norway
Phone: +47 72 89 89 00
Fax: +47 72 89 89 89

Mailing address: Nordic Semiconductor
P.O. Box 2336
7004 Trondheim
Norway



RoHS and REACH statement

Nordic Semiconductor's products meet the requirements of Directive 2002/95/EC of the European Parliament and of the Council on the Restriction of Hazardous Substances (RoHS) and the requirements of the REACH regulation (EC 1907/2006) on Registration, Evaluation, Authorization and Restriction of Chemicals. The SVHC (Substances of Very High Concern) candidate list is continually being updated. Complete hazardous substance reports, material composition reports and latest version of Nordic's REACH statement can be found on our website www.nordicsemi.com.

Datasheet Status

| Status | Description |
|---|---|
| Objective Product Specification (OPS) | This product specification contains target specifications for product development. |
| Preliminary Product Specification (PPS) | This product specification contains preliminary data; supplementary data may be published from Nordic Semiconductor ASA later. |
| Product Specification (PS) | This product specification contains final product specifications. Nordic Semiconductor ASA reserves the right to make changes at any time without notice in order to improve design and supply the best possible product. |

Revision History

| Date | Version | Description |
|---------------|---------|--|
| May 2016 | 1.2 | <p>Added the QFN32 package variant.</p> <p>Added content:</p> <ul style="list-style-type: none"> • <i>Section 2.2.2 "Pin assignment QFN32"</i> • <i>Section 9.2 "QFN32 package"</i> on page 63 • <i>Section 11.2 "Reference design schematics"</i> on page 72 • <i>Section 11.4 "QCAA QFN32 package"</i> on page 79 <p>Updated content:</p> <ul style="list-style-type: none"> • Key features on the front page • <i>Section 3.7 "GPIO"</i> on page 26 • <i>Section 8.2 "Power management"</i> on page 40 • <i>Section 8.5.7 "Antenna matching network requirements"</i> on page 50 • <i>Section 10.6 "Code ranges and values"</i> on page 67 • <i>Section 10.7 "Product options"</i> on page 69 |
| February 2016 | 1.1 | <p>Updated content:</p> <ul style="list-style-type: none"> • <i>Section 8.5.7 "Antenna matching network requirements"</i> on page 50 |
| February 2016 | 1.0 | <p>Updated content:</p> <ul style="list-style-type: none"> • <i>Chapter 7 "Operating conditions"</i> on page 34 • <i>Section 8.1.5 "32.768 kHz crystal oscillator (32k XOSC)"</i> on page 38 • <i>Section 8.1.6 "32.768 kHz RC oscillator (32k RCOSC)"</i> on page 39 • <i>Section 8.5.2 "Radio current consumption with DC/DC disabled"</i> on page 45 • <i>Section 8.5.3 "Radio current consumption with DC/DC enabled"</i> on page 46 • <i>Section 8.15 "Temperature sensor (TEMP)"</i> on page 57 |

| Date | Version | Description |
|---------------|---------|--|
| November 2015 | 0.7 | Updated content: <ul style="list-style-type: none"> • <i>Section 1.1 "Required reading"</i> on page 7 • <i>Chapter 6 "Absolute maximum ratings"</i> on page 33 • <i>Chapter 7 "Operating conditions"</i> on page 34 • <i>Section 8.1.2 "16 MHz crystal oscillator (16M XOSC)"</i> on page 36 • <i>Section 8.1.4 "16 MHz RC oscillator (16M RCOSC)"</i> on page 38 • <i>Chapter 8.1.5 "32.768 kHz crystal oscillator (32k XOSC)"</i> on page 38 • <i>Section 8.2 "Power management"</i> on page 40 • <i>Section 8.4 "CPU"</i> on page 44 • <i>Section 8.5.4 "Transmitter specifications"</i> on page 47 • <i>Section 8.5.5 "Receiver specifications"</i> on page 48 • <i>Section 8.8 "Serial Peripheral Interface Slave (SPIS) specifications"</i> on page 52 • <i>Section 8.12 "Analog to Digital Converter (ADC) specifications"</i> on page 56 • <i>Section 11.3 "QFAA QFN48 package"</i> on page 73 |
| January 2015 | 0.5 | First release. |

Table of contents

| | | |
|----------|---|-----------|
| 1 | Introduction..... | 7 |
| 1.1 | Required reading..... | 7 |
| 1.2 | Writing conventions..... | 7 |
| 2 | Product overview..... | 8 |
| 2.1 | Block diagram | 8 |
| 2.2 | Pin assignments and functions | 9 |
| 3 | System blocks..... | 15 |
| 3.1 | CPU | 15 |
| 3.2 | Memory | 16 |
| 3.3 | Memory Protection Unit (MPU) | 18 |
| 3.4 | Power management (POWER) | 19 |
| 3.5 | Programmable Peripheral Interconnect (PPI) | 22 |
| 3.6 | Clock management (CLOCK) | 23 |
| 3.7 | GPIO..... | 26 |
| 3.8 | Debugger support | 26 |
| 4 | Peripheral blocks | 27 |
| 4.1 | 2.4 GHz radio (RADIO) | 27 |
| 4.2 | Timer/counters (TIMER)..... | 28 |
| 4.3 | Real Time Counter (RTC) | 28 |
| 4.4 | AES Electronic Codebook Mode Encryption (ECB) | 28 |
| 4.5 | AES CCM Mode Encryption (CCM)..... | 29 |
| 4.6 | Accelerated Address Resolver (AAR) | 29 |
| 4.7 | Random Number Generator (RNG) | 29 |
| 4.8 | Watchdog Timer (WDT)..... | 29 |
| 4.9 | Temperature sensor (TEMP) | 30 |
| 4.10 | Serial Peripheral Interface (SPI/SPIS) | 30 |
| 4.11 | Two-wire interface (TWI)..... | 30 |
| 4.12 | Universal Asynchronous Receiver/Transmitter (UART) | 31 |
| 4.13 | Quadrature Decoder (QDEC) | 31 |
| 4.14 | Analog to Digital Converter (ADC) | 31 |
| 4.15 | GPIO Task Event blocks (GPiOTE)..... | 31 |
| 4.16 | Low Power Comparator (LPCOMP)..... | 31 |
| 5 | Instance table | 32 |
| 6 | Absolute maximum ratings | 33 |
| 7 | Operating conditions..... | 34 |
| 8 | Electrical specifications | 35 |
| 8.1 | Clock sources | 35 |
| 8.2 | Power management..... | 40 |
| 8.3 | Block resource requirements | 44 |
| 8.4 | CPU | 44 |
| 8.5 | Radio transceiver | 45 |
| 8.6 | Received Signal Strength Indicator (RSSI) specifications..... | 50 |
| 8.7 | Universal Asynchronous Receiver/Transmitter (UART) specifications | 51 |
| 8.8 | Serial Peripheral Interface Slave (SPIS) specifications | 52 |
| 8.9 | Serial Peripheral Interface (SPI) Master specifications | 53 |

| | | |
|-----------|---|-----------|
| 8.10 | I2C compatible Two Wire Interface (TWI) specifications..... | 54 |
| 8.11 | GPIO Tasks and Events (GPIOTE) specifications..... | 55 |
| 8.12 | Analog to Digital Converter (ADC) specifications..... | 56 |
| 8.13 | Timer (TIMER) specifications..... | 57 |
| 8.14 | Real Time Counter (RTC) | 57 |
| 8.15 | Temperature sensor (TEMP) | 57 |
| 8.16 | Random Number Generator (RNG) specifications..... | 58 |
| 8.17 | AES Electronic Codebook Mode Encryption (ECB) specifications..... | 58 |
| 8.18 | AES CCM Mode Encryption (CCM) specifications | 58 |
| 8.19 | Accelerated Address Resolver (AAR) specifications..... | 58 |
| 8.20 | Watchdog Timer (WDT) specifications | 59 |
| 8.21 | Quadrature Decoder (QDEC) specifications | 59 |
| 8.22 | Non-Volatile Memory Controller (NVMC) specifications..... | 60 |
| 8.23 | General Purpose I/O (GPIO) specifications..... | 61 |
| 8.24 | Low Power Comparator (LPCOMP) specifications..... | 61 |
| 9 | Mechanical specifications | 62 |
| 9.1 | QFN48 package | 62 |
| 9.2 | QFN32 package | 63 |
| 10 | Ordering information | 64 |
| 10.1 | Chip marking..... | 64 |
| 10.2 | Inner box label..... | 64 |
| 10.3 | Outer box label..... | 65 |
| 10.4 | Order code | 65 |
| 10.5 | Abbreviations..... | 66 |
| 10.6 | Code ranges and values | 67 |
| 10.7 | Product options | 69 |
| 11 | Reference circuitry..... | 70 |
| 11.1 | PCB guidelines..... | 70 |
| 11.2 | Reference design schematics..... | 72 |
| 11.3 | QFAA QFN48 package | 73 |
| 11.4 | QCAA QFN32 package | 79 |
| 12 | Glossary | 85 |

1 Introduction

The nRF51802 is an ultra-low power 2.4 GHz wireless System on Chip (SoC) integrating the nRF51 series 2.4 GHz transceiver, a 32 bit ARM® Cortex™-M0 CPU, flash memory, and analog and digital peripherals. nRF51802 can support *Bluetooth*® low energy and a range of proprietary 2.4 GHz protocols, such as Gazell from Nordic Semiconductor.

Fully qualified *Bluetooth* low energy stacks for nRF51802 are implemented in the S100 series of SoftDevices. The S100 series of SoftDevices are available for free and can be downloaded and installed on nRF51802 independent of your own application code.

1.1 Required reading

The following documentation is available for download from our [Infocenter](#):

- *nRF51 Series Reference Manual*
- *nRF51802-PAN (Product Anomaly Notification)*

1.2 Writing conventions

This product specification follows a set of typographic rules to ensure that the document is consistent and easy to read. The following writing conventions are used:

- Command, event names, and bit state conditions, are written in `Lucida Console`.
- Pin names and pin signal conditions are written in `Consolas`.
- File names and User Interface components are written in **bold**.
- Internal cross references are italicized and written in *semi-bold*.
- Placeholders for parameters are written in italic regular text font. For example, a syntax description of Connect will be written as:
`Connect(TimeOut, AdvInterval).`
- Fixed parameters are written in regular text font. For example, a syntax description of Connect will be written as:
`Connect(0x00F0, Interval).`

2 Product overview

2.1 Block diagram

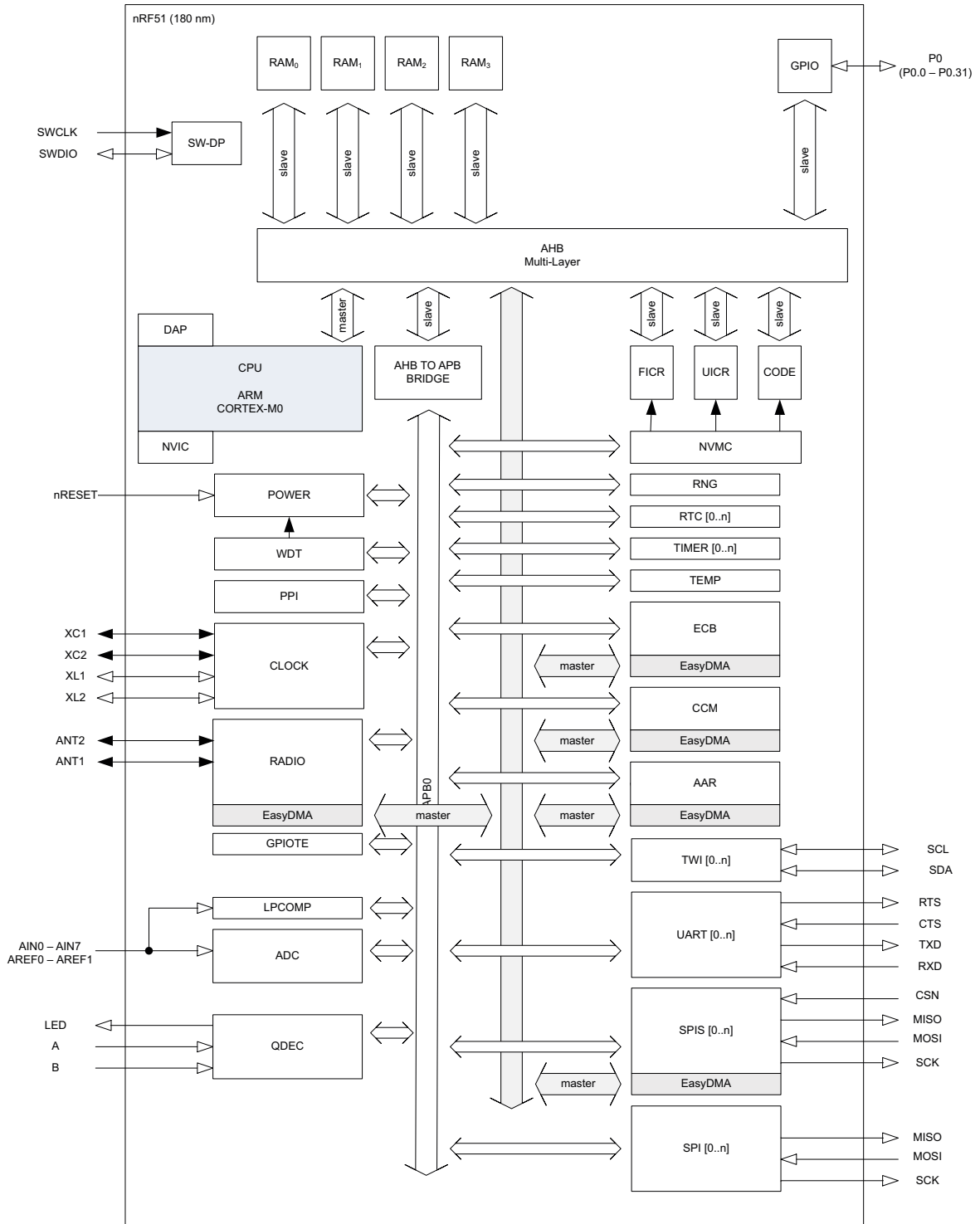

Figure 1 Block diagram

2.2 Pin assignments and functions

This section describes the pin assignment and the pin functions.

2.2.1 Pin assignment QFN48

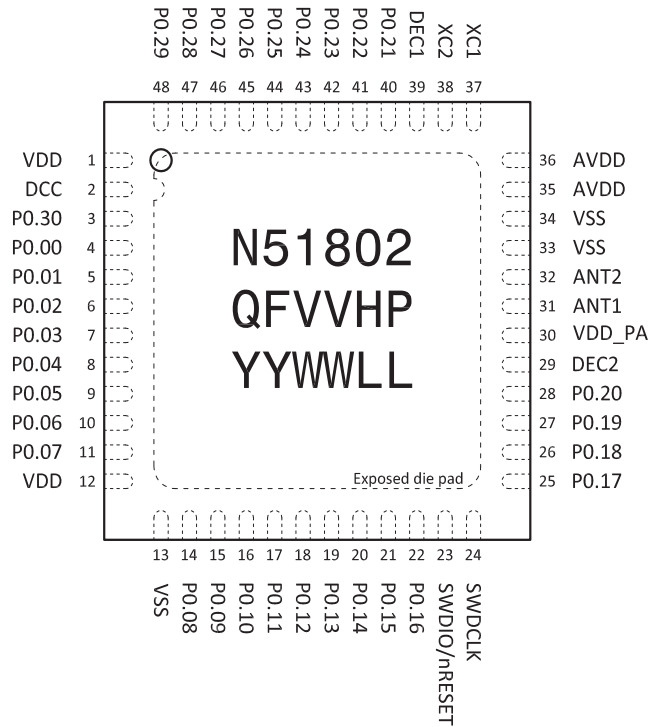

Figure 2 Pin assignment - QFN48 package

Note: VV = Variant code, HP = Build code, YYWWLL = Tracking code.
For more information, see [Section 10.6 "Code ranges and values"](#) on page 67.

2.2.1.1 Pin functions QFN48

| Pin | Pin name | Pin function | Description |
|----------|------------------------|---|--|
| 1 | VDD | Power | Power supply. |
| 2 | DCC | Power | DC/DC output voltage to external LC filter. |
| 3 | P0.30 | Digital I/O | General purpose I/O pin. |
| 4 | P0.00 AREF0 | Digital I/O Analog input | General purpose I/O pin. ADC/LPCOMP reference input 0. |
| 5 | P0.01 AIN2 | Digital I/O Analog input | General purpose I/O pin. ADC/LPCOMP input 2. |
| 6 | P0.02 AIN3 | Digital I/O Analog input | General purpose I/O pin. ADC/LPCOMP input 3. |
| 7 | P0.03 AIN4 | Digital I/O Analog input | General purpose I/O pin. ADC/LPCOMP input 4. |
| 8 | P0.04 AIN5 | Digital I/O Analog input | General purpose I/O pin. ADC/LPCOMP input 5. |
| 9 | P0.05 AIN6 | Digital I/O Analog input | General purpose I/O pin. ADC/LPCOMP input 6. |
| 10 | P0.06 AIN7 AREF1 | Digital I/O Analog input Analog input | General purpose I/O pin. ADC/LPCOMP input 7. ADC/LPCOMP reference input 1. |
| 11 | P0.07 | Digital I/O | General purpose I/O pin. |
| 12 | VDD | Power | Power supply. |
| 13 | VSS | Power | Ground (0 V) ¹ . |
| 14 to 22 | P0.08 to P0.16 | Digital I/O | General purpose I/O pin. |
| 23 | SWDIO/nRESET | Digital I/O | System reset (active low). Also hardware debug and flash programming I/O. |
| 24 | SWDCLK | Digital input | Hardware debug and flash programming I/O. |
| 25 to 28 | P0.17 to P0.20 | Digital I/O | General purpose I/O pin. |
| 29 | DEC2 | Power | Power supply decoupling. |
| 30 | VDD_PA | Power output | Power supply output (+1.6 V) for on-chip RF power amp. |
| 31 | ANT1 | RF | Differential antenna connection (TX and RX). |
| 32 | ANT2 | RF | Differential antenna connection (TX and RX). |
| 33, 34 | VSS | Power | Ground (0 V). |
| 35, 36 | AVDD | Power | Analog power supply (Radio). |
| 37 | XC1 | Analog input | Connection for 16/32 MHz crystal or external 16 MHz clock reference. |
| 38 | XC2 | Analog output | Connection for 16/32 MHz crystal. |
| 39 | DEC1 | Power | Power supply decoupling. |

| Pin | Pin name | Pin function | Description |
|----------|-----------------|---------------|---|
| 40 to 44 | P0.21 to P0.25 | Digital I/O | General purpose I/O pin. |
| 45 | P0.26 | Digital I/O | General purpose I/O pin. |
| | AIN0 | Analog input | ADC/LPCOMP input 0. |
| | XL2 | Analog output | Connection for 32.768 kHz crystal. |
| 46 | P0.27 | Digital I/O | General purpose I/O pin. |
| | AIN1 | Analog input | ADC/LPCOMP input 1. |
| | XL1 | Analog input | Connection for 32.768 kHz crystal or external 32.768 kHz clock reference. |
| 47, 48 | P0.28 and P0.29 | Digital I/O | General purpose I/O pin. |

1. The exposed center pad of the QFN48 package must be connected to ground for proper device operation.

Table 1 Pin functions QFN48 package

2.2.2 Pin assignment QFN32

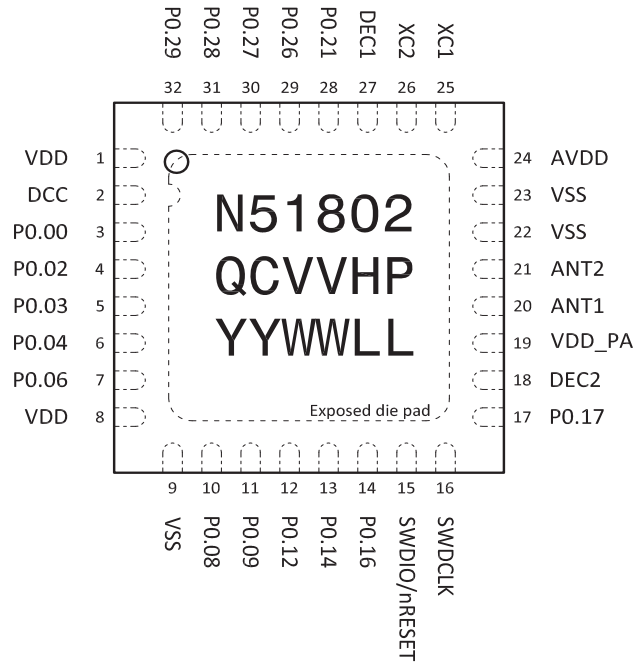

Figure 3 Pin assignment - QFN32 package

Note: VV = Variant code, HP = Build code, YYWWLL = Tracking code.
For more information, see *Section 10.6 "Code ranges and values"* on page 67.

2.2.2.1 Pin functions QFN32

| Pin | Pin name | Pin function | Description |
|-----|------------------------|---|--|
| 1 | VDD | Power | Power supply. |
| 2 | DCC | Power | DC/DC output voltage to external LC filter. |
| 3 | P0.00 AREF0 | Digital I/O Analog input | General purpose I/O pin. ADC/LPCOMP reference input 0. |
| 4 | P0.02 AIN3 | Digital I/O Analog input | General purpose I/O pin. ADC/LPCOMP input 3. |
| 5 | P0.03 AIN4 | Digital I/O Analog input | General purpose I/O pin. ADC/LPCOMP input 4. |
| 6 | P0.04 AIN5 | Digital I/O Analog input | General purpose I/O pin. ADC/LPCOMP input 5. |
| 7 | P0.06 AIN7 AREF1 | Digital I/O Analog input Analog input | General purpose I/O pin. ADC/LPCOMP input 7. ADC/LPCOMP reference input 1. |
| 8 | VDD | Power | Power supply. |
| 9 | VSS | Power | Ground (0 V) ¹ . |
| 10 | P0.08 | Digital I/O | General purpose I/O pin. |
| 11 | P0.09 | Digital I/O | General purpose I/O pin. |
| 12 | P0.12 | Digital I/O | General purpose I/O pin. |
| 13 | P0.14 | Digital I/O | General purpose I/O pin. |
| 14 | P0.16 | Digital I/O | General purpose I/O pin. |
| 15 | SWDIO/nRESET | Digital I/O | System reset (active low). Also hardware debug and flash programming I/O. |
| 16 | SWDCLK | Digital input | Hardware debug and flash programming I/O. |
| 17 | P0.17 | Digital I/O | General purpose I/O pin. |
| 18 | DEC2 | Power | Power supply decoupling. |
| 19 | VDD_PA | Power output | Power supply output (+1.6 V) for on-chip RF power amp. |
| 20 | ANT1 | RF | Differential antenna connection (TX and RX). |
| 21 | ANT2 | RF | Differential antenna connection (TX and RX). |
| 22 | VSS | Power | Ground (0 V). |
| 23 | VSS | Power | Ground (0 V). |
| 24 | AVDD | Power | Analog power supply (Radio). |
| 25 | XC1 | Analog input | Connection for 16/32 MHz crystal or external 16 MHz clock reference. |
| 26 | XC2 | Analog output | Connection for 16/32 MHz crystal. |
| 27 | DEC1 | Power | Power supply decoupling. |

| Pin | Pin name | Pin function | Description |
|-----|----------|---------------|------------------------------------|
| 28 | P0.21 | Digital I/O | General purpose I/O pin. |
| 29 | P0.26 | Digital I/O | General purpose I/O pin. |
| | AIN0 | Analog input | ADC/LPCOMP input 0. |
| 30 | XL2 | Analog output | Connection for 32.768 kHz crystal. |
| | P0.27 | Digital I/O | General purpose I/O pin. |
| | AIN1 | Analog input | ADC/LPCOMP input 1. |
| 31 | P0.28 | Digital I/O | General purpose I/O pin. |
| 32 | P0.29 | Digital I/O | General purpose I/O pin. |

1. The exposed center pad of the QFN32 package must be connected to ground for proper device operation.

Table 2 Pin functions QFN32 package

3 System blocks

The chip contains system-level features common to all nRF51 series devices including clock control, power and reset, interrupt system, Programmable Peripheral Interconnect (PPI), watchdog, and GPIO.

System blocks which have a register interface and/or interrupt vector assigned are instantiated in the device address space. The instances of system blocks, their associated ID (for those with interrupt vectors), and base addresses are found in **Table 16** on page 32. Detailed functional descriptions, configuration options, and register interfaces can be found in the *nRF51 Series Reference Manual*.

3.1 CPU

The ARM® Cortex™-M0 CPU has a 16 bit instruction set with 32 bit extensions (**Thumb-2® technology**) that delivers high-density code with a small-memory-footprint. By using a single-cycle 32 bit multiplier, a 3-stage pipeline, and a Nested Vector Interrupt Controller (NVIC), the ARM Cortex-M0 CPU makes program execution simple and highly efficient.

The ARM Cortex Microcontroller Software Interface Standard (CMSIS) hardware abstraction layer for the ARM Cortex-M processor series is implemented and available for M0 CPU. Code is forward compatible with ARM Cortex M3 based devices.

3.2 Memory

All memory and registers are found in the same address space as shown in the Device Memory Map, see **Figure 4**. Devices in the nRF51 series use flash based memory in the code, FICR, and UICR regions. The RAM region is SRAM.

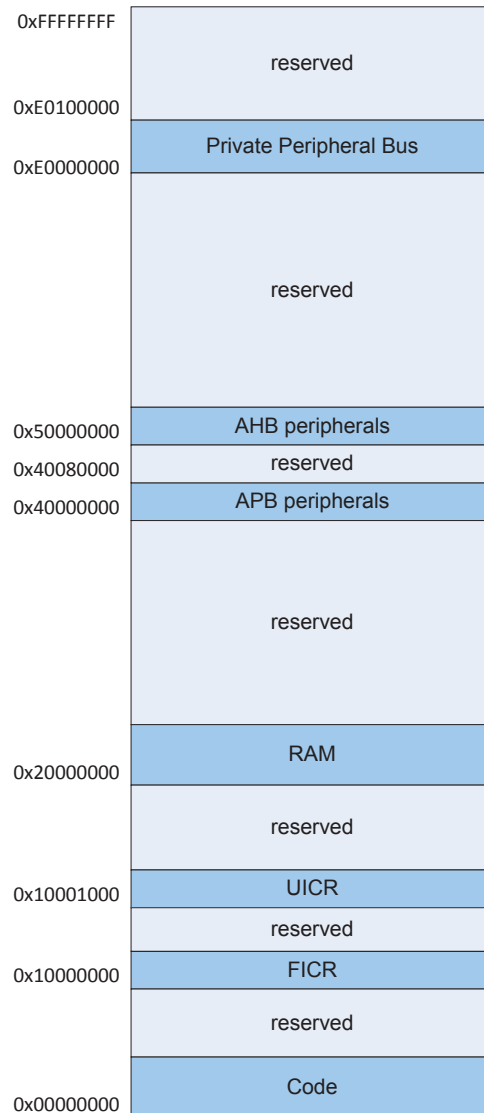

Figure 4 Memory Map

The embedded flash memory for program and static data can be programmed using In Application Programming (IAP) routines from RAM through the SWD interface, or in-system from a program executing from code area. The Non-Volatile Memory Controller (NVMC) is used for program/erase operations. Regions of flash memory can be protected from read, write, and erase by the Memory Protection Unit (MPU). A User Information Configuration Register (UICR) contains the lock byte for enabling readback protection to secure the IP, while individual block protection is controlled using registers which can only be cleared on chip reset.

3.2.1 Code organization

| Chip variant | Code size | Page size | No of pages |
|--------------------------------|-----------|-----------|-------------|
| nRF51802-QFAA nRF51802-QCAA | 256 kB | 1024 byte | 256 |

Table 3 Code organization

3.2.2 RAM organization

RAM is divided into blocks for separate power management which is controlled by the POWER System Block. Each block is divided into two 4 kByte RAM sections with separate RAM AHB slaves. Please see the *nRF51 Series Reference Manual* for more information.

| Chip variant | RAM size | Block | Size |
|--------------------------------|----------|------------------|--------------|
| nRF51802-QFAA nRF51802-QCAA | 16 kB | Block0 Block1 | 8 kB 8 kB |

Table 4 RAM organization

How to organize the use of the RAM

For the best performance we recommend the following use of the RAM AHB slaves (Note that the Crypto consists of CCM, ECB, and AAR modules):

- If the Radio and Crypto buffers together are larger in size than one RAM section, the buffers should be separated so the memory used by the Radio is in one RAM section while the memory used by the Crypto is in another RAM section.
- The sections used by CODE should not be combined with sections used by the Radio, Crypto, or SPI.
- The Stack and Heap should be placed at the top section and should not be combined with sections used by the Radio, Crypto, or SPI.

Table 5 shows how memory allocated to different functions can be distributed between RAM sections for parallel access.

| RAM Blocks/Sections | | Radio buffers | Crypto buffers | SPIS buffers | CPU Stack/Heap | CODE | Global variables |
|---------------------|------|---------------|----------------|--------------|----------------|------|------------------|
| Block0 | RAM0 | x | x | | | | x |
| | RAM1 | | | | | x | x |
| Block1 | RAM2 | | | x | | | x |
| | RAM3 | | | | x | x | x |

Table 5 16 kB RAM variants

3.3 Memory Protection Unit (MPU)

The memory protection unit can be configured to protect all flash memory on the device from read-back, or to protect blocks of flash from over-write or erase.

| Chip variant | Flash block size | Number of protectable Flash blocks |
|--------------------------------|------------------|------------------------------------|
| nRF51802-QFAA nRF51802-QCAA | 4 kB | 64 |

Table 6 MPU flash blocks

3.4 Power management (POWER)

3.4.1 Power supply

nRF51 supports three different power supply alternatives:

- Internal LDO setup
- DC/DC converter setup
- Low voltage mode setup

See **Table 18** on page 34 for the voltage range on the different alternatives. See **Chapter 11 “Reference circuitry”** on page 70 for details on the schematic used for the different power supply alternatives.

3.4.1.1 Internal LDO setup

In internal LDO mode the DC/DC converter is bypassed (disabled) and the system power is generated directly from the supply voltage VDD. This mode could be used as the only option or in combination with the DC/DC converter setup. See DC/DC converter section for more details.

3.4.1.2 DC/DC converter setup

The nRF51 DC/DC buck converter transforms battery voltage to lower internal voltage with minimal power loss. The converted voltage is then available for the linear regulator input. The DC/DC converter can be disabled when the supply voltage drops to the lower limit of the voltage range so the LDO can be used for low supply voltages. When enabled, the DC/DC converter operation is automatically suspended between radio events when only the low current regulator is needed internally.

This feature is particularly useful for applications using battery technologies with nominal cell voltages higher than the minimum supply voltage with DC/DC enabled. The reduction in supply voltage level from a high voltage to a low voltage reduces the peak power drain from the battery. Used with a 3 V coin-cell battery, the peak current drawn from the battery is reduced by approximately 25%.

3.4.1.3 Low voltage mode setup

Devices can be used in low voltage mode where a steady 1.8 V supply is available externally.

3.4.2 Power management

The power management system is highly flexible with functional blocks such as the CPU, Radio Transceiver, and peripherals having separate power state control in addition to the global System ON and OFF modes. In System OFF mode, RAM can be retained and the device state can be changed to System ON through Reset, GPIO DETECT signal, or LPCOMP ANADETECT signal. When in System ON mode, all functional blocks will independently be in IDLE or RUN mode depending on needed functionality.

Power management features:

- Supervisor HW to manage
 - Power on reset
 - Brownout reset
 - Power fail comparator
- System ON/OFF modes
- Pin wake-up from System OFF
 - Reset
 - GPIO DETECT signal
 - LPCOMP ANADETECT signal
- Functional block RUN/IDLE modes
- RAM retention in System OFF mode (8 kB blocks)
 - 16 kB version will have 2 blocks

3.4.2.1 System OFF mode

In system OFF mode the chip is in the deepest power saving mode. The system's core functionality is powered down and all ongoing tasks are terminated. The only functionality that can be set up to be responsive is the Pin wake-up mechanism.

One or more blocks of RAM can be retained while in System OFF mode.

3.4.2.2 System ON mode

In system ON mode the system is fully operational and the CPU and selected peripherals can be brought into a state where they are functional and more or less responsive depending on the sub-power mode selected.

There are two sub-power modes:

- Low power
- Constant latency

Low Power

In Low Power mode the automatic power management system is optimized to save power. This is done by keeping as much as possible of the system powered down. The cost of this is that you will have varying CPU wakeup latency and PPI task response.

The CPU wakeup latency will be affected by the startup time of the 1V7 regulator. The PPI task response will vary depending on the resources required by the peripheral where the task originated.

The resources that could be involved are:

- 1V7 with the startup time t_{1V7}
- 1V2 with the startup time t_{1V2}
- One of the following clock sources
 - RC16 with the startup time $t_{START,RC16}$
 - XO16M/XO32M with the startup time the clock management system t_{XO} ¹

Constant Latency

In Constant Latency mode the system is optimized towards keeping the CPU latency and the PPI task response constant and at a minimum. This is secured by forcing a set of base resources on while in sleep mode. The cost is that the system will have higher power consumption.

The following resources are kept active while in sleep mode:

- 1V7 regulator with the standby current of I_{1V7}
- 1V2 regulator. Here the current consumption is specified in combination with the clock source
- One of the following clock sources:
 - RC16 with the standby current of $I_{1V2RC16}$
 - XO16M with the standby current of $I_{1V2XO16}$
 - XO32M with the standby current of $I_{1V2XO32}$

1. For the clock source XO16M and XO32M we assume that the crystal is already running (standby). This will give an increase of the power consumption in sleep mode given by $I_{STBY,X16M} / I_{STBY,X32M}$.

3.5 Programmable Peripheral Interconnect (PPI)

The Programmable Peripheral Interconnect (PPI) enables peripherals to interact autonomously with each other using tasks and events independent of the CPU. The PPI allows precise synchronization between peripherals when real-time application constraints exist and eliminates the need for CPU activity to implement behavior which can be predefined using PPI.

| Instance | Channel | Number of channels | Number of groups |
|----------|---------|--------------------|------------------|
| PPI | 0 - 15 | 16 | 4 |

Table 7 PPI properties

The PPI system has in addition to the fully programmable peripheral interconnections, a set of channels where the event (EEP) and task (TEP) endpoints are set in hardware. These fixed channels can be individually enabled, disabled, or added to PPI channel groups in the same way as ordinary PPI channels. See the *nRF51 Series Reference Manual* for more information.

| Instance | Channel | Number of channels | Number of groups |
|----------|---------|--------------------|------------------|
| PPI | 20 - 31 | 12 | 4 |

Table 8 Pre-programmed PPI channels

3.6 Clock management (CLOCK)

The advanced clock management system can source the system clocks from a range of internal or external high and low frequency oscillators and distribute them to modules based upon a module’s individual requirements. This prevents large clock trees from being active and drawing power when system modules needing this clock reference are not active.

If an application enables a module that needs a clock reference without the corresponding oscillator running, the clock management system will automatically enable the RC oscillator option and provide the clock. When the module goes back to idle, the clock management will automatically set the oscillator to idle. To avoid delays involved in starting a given oscillator, or if a specific oscillator is required, the application can override the automatic oscillator management so it keeps oscillators active when no system modules require the clock reference.

Clocks are only available in System ON mode and can be generated by the sources listed in *Table 9*.

| Clock | Source | Frequency options |
|---|---------------------------------------|------------------------|
| High Frequency Clock (HFCLK) ¹ | External Crystal (XOSC) | 16/32 MHz ² |
| | External clock reference ³ | 16 MHz |
| | Internal RC Oscillator (RCOSC) | 16 MHz |
| Low Frequency Clock (LFCLK) | External Crystal (XOSC) | 32.768 kHz |
| | External clock reference ³ | 32.768 kHz |
| | Synthesized from HFCLK | 32.768 kHz |
| | Internal RC Oscillator (RCOSC) | 32.768 kHz |

1. External Crystal must be used for Radio operation.
2. The HFCLK will be 16 MHz for both the 16 and 32 MHz crystal option.
3. See the *nRF51 Series Reference Manual* for more details on external clock reference.

Table 9 Clock properties

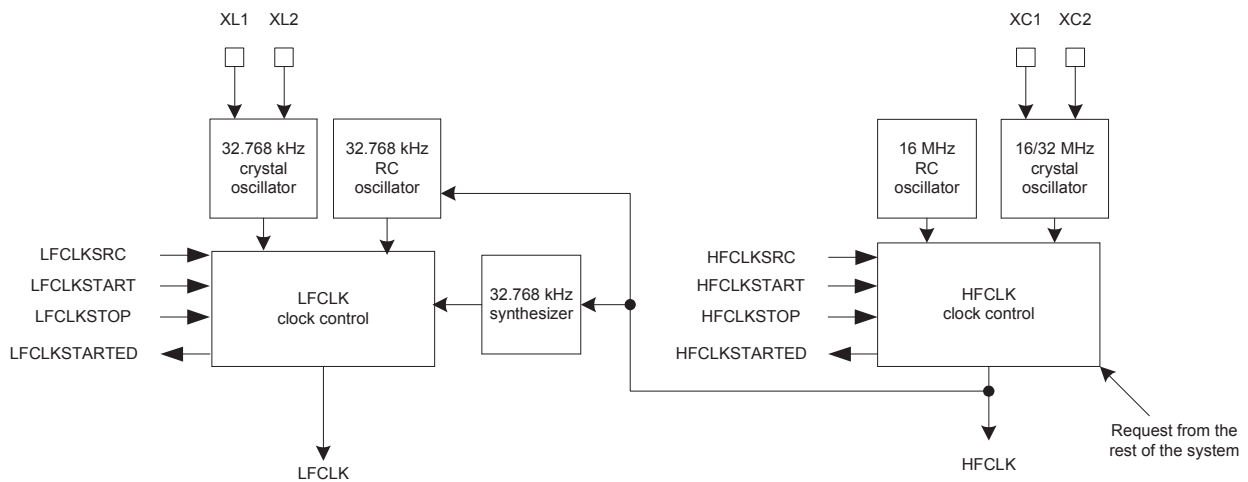

Figure 5 Clock management

3.6.1 16/32 MHz crystal oscillator

The crystal oscillator can be controlled either by a 16 MHz or a 32 MHz external crystal. However, the system clock is always 16 MHz, see the *nRF51 Series Reference Manual* for more details. The crystal oscillator is designed for use with an AT-cut quartz crystal in parallel resonant mode. To achieve correct oscillation frequency, the load capacitance must match the specification in the crystal data sheet. **Figure 6** shows how the crystal is connected to the 16/32 MHz crystal oscillator.

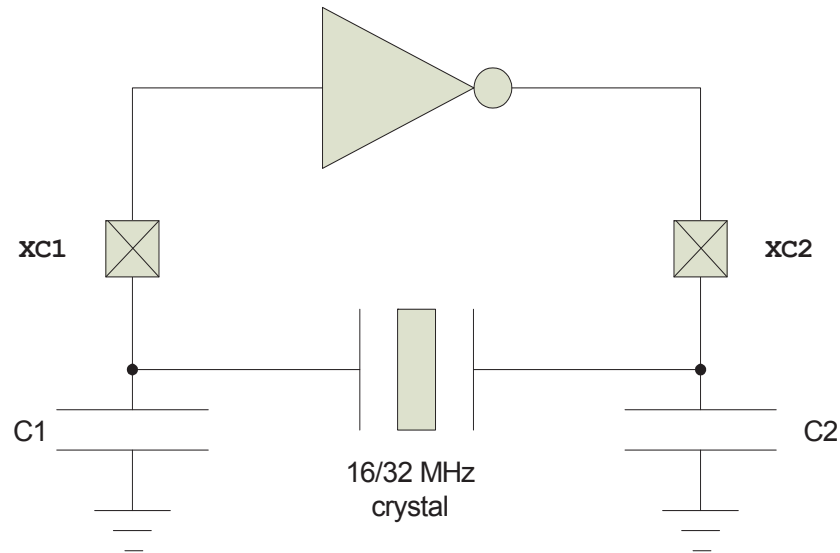

Figure 6 Circuit diagram of the 16/32 MHz crystal oscillator

The load capacitance (C_L) is the total capacitance seen by the crystal across its terminals and is given by:

$$C_L = \frac{(C1' \cdot C2')}{(C1' + C2')}$$

$$C1' = C1 + C_{pcb1} + C_{pin}$$

$$C2' = C2 + C_{pcb2} + C_{pin}$$

$C1$ and $C2$ are ceramic SMD capacitors connected between each crystal terminal and ground. C_{pcb1} and C_{pcb2} are stray capacitances on the PCB. C_{pin} is the pin input capacitance on the XC1 and XC2 pins, see **Table 20** on page 36 (16 MHz) and **Table 21** on page 37 (32 MHz). The load capacitors $C1$ and $C2$ should have the same value. See **Chapter 11 "Reference circuitry"** on page 70 for the capacitance value used for C_{pcb1} and C_{pcb2} in reference circuitry.

For reliable operation, the crystal load capacitance, shunt capacitance, equivalent series resistance ($R_{S,X16M}/R_{S,X32M}$), and drive level must comply with the specifications in **Table 20** on page 36 (16 MHz) and **Table 21** on page 37 (32 MHz). It is recommended to use a crystal with lower than maximum $R_{S,X16M}/R_{S,X32M}$ if the load capacitance and/or shunt capacitance is high. This will give faster startup and lower current consumption. A low load capacitance will reduce both startup time and current consumption.

3.6.2 32.768 kHz crystal oscillator

The 32.768 kHz crystal oscillator is designed for use with a quartz crystal in parallel resonant mode. To achieve correct oscillation frequency, the load capacitance must match the specification in the crystal data sheet. **Figure 7** shows how the crystal is connected to the 32.768 kHz crystal oscillator.

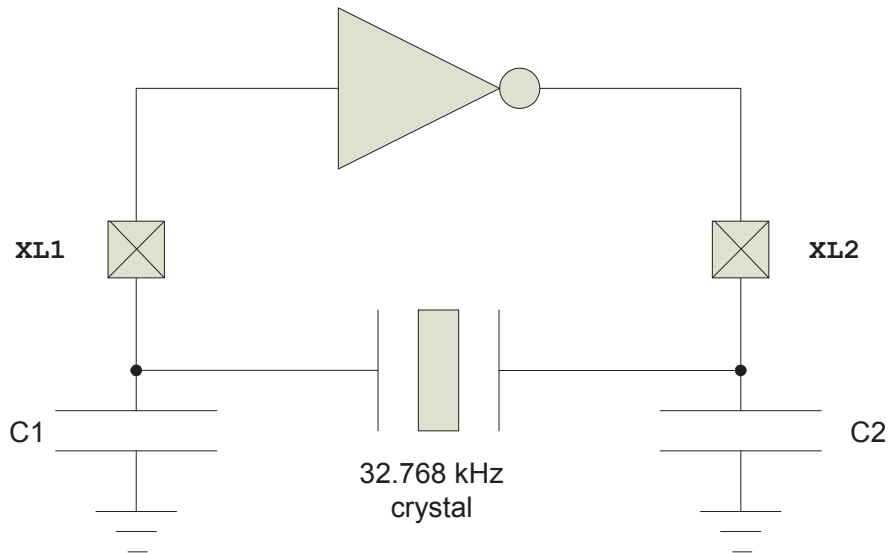

Figure 7 Circuit diagram of the 32.768 kHz crystal oscillator

The load capacitance (CL) is the total capacitance seen by the crystal across its terminals and is given by:

$$CL = \frac{(C1' \cdot C2')}{(C1' + C2')}$$

$$C1' = C1 + C_{pcb1} + C_{pin}$$

$$C2' = C2 + C_{pcb2} + C_{pin}$$

C1 and C2 are ceramic SMD capacitors connected between each crystal terminal and ground. C_pcb1 and C_pcb2 are stray capacitances on the PCB. C_pin is the pin input capacitance on the XC1 and XC2 pins, see **Section 8.1.5 "32.768 kHz crystal oscillator (32k XOSC)"** on page 38. The load capacitors C1 and C2 should have the same value. See **Chapter 11 "Reference circuitry"** on page 70 for the capacitance value used for C_pcb1 and C_pcb2 in reference circuitry.

3.6.3 32.768 kHz RC oscillator

The 32.768 kHz RC low frequency oscillator may be used as an alternative to the 32.768 kHz crystal oscillator. It has a frequency accuracy of less than ± 250 ppm in a stable temperature environment or when calibration is periodically performed in changing temperature environments. The 32.768 kHz RC oscillator does not require external components.

3.6.4 Synthesized 32.768 kHz clock

The low frequency clock can be synthesized from the high frequency clock. This saves the cost of a crystal but increases average power consumption as the high frequency clock source will have to be active.

3.7 GPIO

The general purpose I/O is organized as one port with up to 31 I/Os (dependent on package) enabling access and control of up to 31 pins through one port. Each GPIO can be accessed individually with the following user configurable features:

- Input/output direction
- Output drive strength
- Internal pull-up and pull-down resistors
- Wake-up from high or low level triggers on all pins
- Trigger interrupt on all pins
- All pins can be used by the PPI task/event system; the maximum number of pins that can be interfaced through the PPI at the same time is limited by the number of GPIOTE channels
- All pins can be individually configured to carry serial interface or quadrature demodulator signals

3.8 Debugger support

The two pin Serial Wire Debug (SWD) interface provided as a part of the Debug Access Port (DAP) offers a flexible and powerful mechanism for non-intrusive debugging of program code. Breakpoints and single stepping are part of this support.

4 Peripheral blocks

Peripheral blocks which have a register interface and/or interrupt vector assigned are instantiated, one or more times, in the device address space. The instances, associated ID (for those with interrupt vectors), and base address of features are found in **Table 16** on page 32. Detailed functional descriptions, configuration options, and register interfaces can be found in the *nRF51 Series Reference Manual*.

4.1 2.4 GHz radio (RADIO)

The nRF51 series 2.4 GHz RF transceiver is designed and optimized to operate in the worldwide ISM frequency band at 2.400 to 2.4835 GHz. Radio modulation modes and configurable packet structure enable interoperability with *Bluetooth*® low energy (BLE), Enhanced ShockBurst™, and other 2.4 GHz protocol implementations.

The transceiver receives and transmits data directly to and from system memory for flexible and efficient packet data management. The nRF51 series transceiver has the following features:

- General modulation features
 - GFSK modulation
 - Data whitening
 - On-air data rates
 - 250 kbps
 - 1 Mbps
 - 2 Mbps
- Transmitter with programmable output power of +4 dBm to -20 dBm, in 4 dB steps
- Transmitter whisper mode -30 dBm
- RSSI function (1 dB resolution)
- Receiver with integrated channel filters achieving typical sensitivity
 - -94 dBm at 250 kbps
 - -91 dBm at 1 Mbps BLE
 - -88 dBm at 1 Mbps
 - -83 dBm at 2 Mbps
- RF Synthesizer
 - 1 MHz frequency programming resolution
 - 1 MHz non-overlapping channel spacing at 1 Mbps and 250 kbps
 - 2 MHz non-overlapping channel spacing at 2 Mbps
 - Works with low-cost ± 60 ppm 16 MHz crystal oscillators
- Baseband controller
 - EasyDMA RX and TX packet transfer directly to and from RAM
 - Dynamic payload length
 - On-the-fly packet assembly/disassembly and AES CCM payload encryption
 - 8 bit, 16 bit, and 24 bit CRC check (programmable polynomial and initial value)

Note: EasyDMA is an integrated DMA implementation requiring no configuration to take advantage of flexible data management and avoids copying operations to and from RAM.

4.2 Timer/counters (TIMER)

The timer/counter runs on the high-frequency clock source (HFCLK) and includes a 4 bit ($1/2^X$) prescaler that can divide the HFCLK.

The TIMER will start requesting the 1 MHz mode of the HFCLK for values of the prescaler that gives f_{TIMER} less or equal to 1 MHz. If the timer module is the only one requesting the HFCLK, the system will automatically switch to using the 1 MHz mode resulting in a decrease in the current consumption. See the parameters $I_{1V2XO16,1M}$, $I_{1V2XO32,1M}$, $I_{1V2RC16,1M}$ in **Table 30** on page 43 and $I_{\text{TIMER0}/1/2,1M}$ in **Table 50** on page 57.

The task/event and interrupt features make it possible to use the PPI system for timing and counting tasks between any system peripheral including any GPIO of the device. The PPI system also enables the TIMER task/event features to generate periodic output and PWM signals to any GPIO. The number of input/outputs used at the same time is limited by the number of GPIOTE channels.

| Instance | Bit-width | Capture/Compare registers |
|----------|------------|---------------------------|
| TIMER0 | 8/16/24/32 | 4 |
| TIMER1 | 8/16 | 4 |
| TIMER2 | 8/16 | 4 |

Table 10 Timer/counter properties

4.3 Real Time Counter (RTC)

The Real Time Counter (RTC) module provides a generic, low power timer on the low-frequency clock source (LFCLK). The RTC features a 24 bit COUNTER, 12 bit ($1/X$) prescaler, capture/compare registers, and a tick event generator for low power, tickless RTOS implementation.

| Instance | Capture/Compare registers |
|----------|---------------------------|
| RTC0 | 3 |
| RTC1 | 4 |

Table 11 RTC properties

4.4 AES Electronic Codebook Mode Encryption (ECB)

The ECB encryption block supports 128 bit AES block encryption. It can be used for a range of cryptographic functions like hash generation, digital signatures, and keystream generation for data encryption/decryption. ECB encryption uses EasyDMA to access system RAM for in-place operations on cleartext and ciphertext during encryption.

4.5 AES CCM Mode Encryption (CCM)

Cipher Block Chaining - Message Authentication Code (CCM) Mode is an authenticated encryption algorithm designed to provide both authentication and confidentiality during data transfer. CCM combines counter mode encryption and CBC-MAC authentication.

Note: The CCM terminology "Message Authentication Code (MAC)" is called the "Message Integrity Check (MIC)" in *Bluetooth* terminology and this document and the *nRF51 Series Reference Manual* are consistent with *Bluetooth* terminology.

The CCM block generates an encrypted keystream, applies it to the input data using the XOR operation, and generates the 4 byte MIC field in one operation. The CCM and radio can be configured to work synchronously, as described in the *nRF51 Series Reference Manual*. The CCM will encrypt in time for transmission and decrypt after receiving bytes into memory from the Radio. All operations can complete within the packet RX or TX time.

CCM on this device is implemented according to *Bluetooth* requirements and the algorithm as defined in [IETF RFC3610](#), and depends on the AES-128 block cipher. A description of the CCM algorithm can also be found in the [NIST Special Publication 800-38C](#). The *Bluetooth* Core Specification v4.0 describes the configuration of counter mode blocks and encryption blocks to implement compliant encryption for BLE.

The CCM block uses EasyDMA to load key, counter mode blocks (including the nonce required), and to read/write plain text and cipher text.

4.6 Accelerated Address Resolver (AAR)

Accelerated Address Resolver is a cryptographic support function to implement the "Resolvable Private Address Resolution Procedure" described in the *Bluetooth Core Specification* v4.1. "Resolvable Private Address Generation" should be achieved using ECB and is not supported by AAR. The procedure allows two devices that share a secret key to generate and resolve a hash based on their device address.

The AAR block enables real-time address resolution on incoming packets when configured according to the description in the *nRF51 Series Reference Manual*. This allows real-time packet filtering (whitelisting) using a list of known shared secrets (Identity Resolving Keys (IRK) in *Bluetooth*).

The following table outlines the properties of the AAR.

| Instance | Number of IRKs supported for simultaneous resolution |
|----------|--|
| AAR | 8 |

Table 12 AAR properties

4.7 Random Number Generator (RNG)

The Random Number Generator (RNG) generates true non-deterministic random numbers derived from thermal noise that are suitable for cryptographic purposes. The RNG does not require a seed value.

4.8 Watchdog Timer (WDT)

A countdown watchdog timer using the low-frequency clock source (LFCLK) offers configurable and robust protection against application lock-up. The watchdog can be paused during long CPU sleep periods for low power applications and when the debugger has halted the CPU.

4.9 Temperature sensor (TEMP)

The temperature sensor measures die temperature over the temperature range of the device with 0.25° C resolution.

4.10 Serial Peripheral Interface (SPI/SPIS)

The SPI interfaces enable full duplex synchronous communication between devices. They support a three-wire (SCK, MISO, MOSI) bi-directional bus with fast data transfers. The SPI Master can communicate with multiple slaves using individual chip select signals for each of the slave devices attached to a bus. Control of chip select signals is left to the application through use of GPIO signals. SPI Master has double buffered I/O data. The SPI Slave includes EasyDMA for data transfer directly to and from RAM allowing Slave data transfers to occur while the CPU is IDLE.

The GPIOs used for each SPI interface line can be chosen from any GPIO on the device and are independently configurable. This enables great flexibility in device pinout and efficient use of printed circuit board space and signal routing.

The SPI peripheral supports SPI mode 0, 1, 2, and 3.

| Instance | Master/Slave |
|----------|--------------|
| SPI0 | Master |
| SPI1 | Master |
| SPIS1 | Slave |

Table 13 SPI properties

4.10.1 Enable 4 Mbps SPIS bit rate

In order to utilize 4 Mbps bit rate for SPIS, the SPIS must be the only peripheral using a specific RAM section. Construction of RAM sections are described in **Section 3.2.2 “RAM organization”** on page 17. If other peripherals than SPIS use a specific RAM section, only 2 Mbps bit rate is possible.

4.11 Two-wire interface (TWI)

The two-wire interface can communicate with a bi-directional wired-AND bus with two lines (SCL, SDA). The protocol makes it possible to interconnect up to 127 individually addressable devices. The interface is capable of clock stretching, supporting data rates of 100 kbps and 400 kbps.

The GPIOs used for each two-wire interface line can be chosen from any GPIO on the device and are independently configurable. This enables great flexibility in device pinout and efficient use of board space and signal routing.

| Instance | Master/Slave |
|----------|--------------|
| TWI0 | Master |
| TWI1 | Master |

Table 14 Two-wire properties

4.12 Universal Asynchronous Receiver/Transmitter (UART)

The Universal Asynchronous Receiver/Transmitter offers fast, full-duplex, asynchronous serial communication with built-in flow control (CTS, RTS) support in hardware up to 1 Mbps baud. Parity checking is supported.

The GPIOs used for each UART interface line can be chosen from any GPIO on the device and are independently configurable. This enables great flexibility in device pinout and efficient use of board space and signal routing.

4.13 Quadrature Decoder (QDEC)

The quadrature decoder provides buffered decoding of quadrature-encoded sensor signals. It is suitable for mechanical and optical sensors with an optional LED output signal and input debounce filters. The sample period and accumulation are configurable to match application requirements.

4.14 Analog to Digital Converter (ADC)

The 10 bit incremental Analog to Digital Converter (ADC) enables sampling of up to 8 external signals through a front-end multiplexer. The ADC has configurable input and reference prescaling, and sample resolution (8, 9, and 10 bit).

Note: The ADC module uses the same analog inputs as the LPCOMP module (AIN0 - AIN7 and AREF0 - AREF1). Only one of the modules can be enabled at the same time.

4.15 GPIO Task Event blocks (GPIOTE)

A GPIOTE block enables GPIOs on Port 0 to generate events on pin state change which can be used to carry out tasks through the PPI system. A GPIO can also be driven to change state on system events using the PPI system. Low power detection of pin state changes on Port 0 is possible when in System ON or System OFF.

| Instance | Number of GPIOTE channels |
|----------|---------------------------|
| GPIOTE | 4 |

Table 15 GPIOTE properties

4.16 Low Power Comparator (LPCOMP)

In System ON, the block can generate separate events on rising and falling edges of a signal, or sample the current state of the pin as being above or below the threshold. The block can be configured to use any of the analog inputs on the device. Additionally, the low power comparator can be used as an analog wakeup source from System OFF or System ON. The comparator threshold can be programmed to a range of fractions of the supply voltage.

Note: The LPCOMP module uses the same analog inputs as the ADC module (AIN0 - AIN7 and AREF0 - AREF1). Only one of the modules can be enabled at the same time.

5 Instance table

The peripheral instantiation of the chip is shown in the table below.

| ID | Base address | Peripheral | Instance | Description |
|---------|--------------|------------|----------|--|
| 0 | 0x40000000 | POWER | POWER | Power Control. |
| 0 | 0x40000000 | CLOCK | CLOCK | Clock Control. |
| 0 | 0x40000000 | MPU | MPU | Memory Protection Unit. |
| 1 | 0x40001000 | RADIO | RADIO | 2.4 GHz Radio. |
| 2 | 0x40002000 | UART | UART0 | Universal Asynchronous Receiver/Transmitter. |
| 3 | 0x40003000 | SPI | SPI0 | SPI Master. |
| 3 | 0x40003000 | TWI | TWI0 | I2C compatible Two-Wire Interface 0. |
| 4 | 0x40004000 | SPIS | SPIS1 | SPI Slave. |
| 4 | 0x40004000 | SPI | SPI1 | SPI Master. |
| 4 | 0x40004000 | TWI | TWI1 | I2C compatible Two-Wire Interface 1. |
| 5 | | | | Unused. |
| 6 | 0x40006000 | GPIOTE | GPIOTE | GPIO Task and Events. |
| 7 | 0x40007000 | ADC | ADC | Analog to Digital Converter. |
| 8 | 0x40008000 | TIMER | TIMER0 | Timer/Counter 0. |
| 9 | 0x40009000 | TIMER | TIMER1 | Timer/Counter 1. |
| 10 | 0x4000A000 | TIMER | TIMER2 | Timer/Counter 2. |
| 11 | 0x4000B000 | RTC | RTC0 | Real Time Counter 0. |
| 12 | 0x4000C000 | TEMP | TEMP | Temperature Sensor. |
| 13 | 0x4000D000 | RNG | RNG | Random Number Generator. |
| 14 | 0x4000E000 | ECB | ECB | Crypto AES ECB. |
| 15 | 0x4000F000 | CCM | CCM | AES Crypto CCM. |
| 15 | 0x4000F000 | AAR | AAR | Accelerated Address Resolver. |
| 16 | 0x40010000 | WDT | WDT | Watchdog Timer. |
| 17 | 0x40011000 | RTC | RTC1 | Real Time Counter 1. |
| 18 | 0x40012000 | QDEC | QDEC | Quadrature Decoder. |
| 19 | 0x40013000 | LPCOMP | LPCOMP | Low Power Comparator. |
| 20 - 25 | | | | Reserved as software interrupt. |
| 26 - 29 | | | | Unused. |
| 30 | 0x4001E000 | NVMC | NVMC | Non-Volatile Memory Controller. |
| 31 | 0x4001F000 | PPI | PPI | Programmable Peripheral Interconnect. |
| NA | 0x50000000 | GPIO | GPIO | General Purpose Input and Output. |
| NA | 0x10000000 | FICR | FICR | Factory Information Configuration Registers. |
| NA | 0x10001000 | UICR | UICR | User Information Configuration Registers. |

Table 16 Peripheral instance reference

6 Absolute maximum ratings

Maximum ratings are the extreme limits the chip can be exposed to without causing permanent damage. Exposure to absolute maximum ratings for prolonged periods of time may affect the reliability of the chip. *Table 17* specifies the absolute maximum ratings.

| Symbol | Parameter | Min. | Max. | Unit |
|--|----------------------------|---------------------|-----------|--------------------|
| Supply voltages | | | | |
| VDD | | -0.3 | +3.9 | V |
| DEC2 | | | 2 | V |
| VSS | | | 0 | V |
| I/O pin voltage | | | | |
| VIO | | -0.3 | VDD + 0.3 | V |
| Environmental | | | | |
| Storage temperature | | -40 | +125 | °C |
| MSL | Moisture Sensitivity Level | | 2 | |
| ESD HBM | Human Body Model | | 2 | kV |
| ESD CDM | Charged Device Model | | 1000 | V |
| Flash memory | | | | |
| Endurance | | 10 000 ¹ | | write/erase cycles |
| Retention | | 10 years at 40 °C | | |
| Number of times an address can be written between erase cycles | | | 2 | times |

1. Flash endurance is 10,000 erase cycles. The smallest element of flash that can be written is a 32 bit word.

Table 17 Absolute maximum ratings



7 Operating conditions

The operating conditions are the physical parameters that the chip can operate within as defined in *Table 18*.

| Symbol | Parameter | Notes | Min. | Typ. | Max. | Units |
|--------------|--|-------|------|------|------|-------|
| VDD | Supply voltage, internal LDO setup | | 1.8 | 3.0 | 3.6 | V |
| VDD | Supply voltage, DC/DC converter setup | | 2.1 | 3.0 | 3.6 | V |
| VDD | Supply voltage, low voltage mode setup | 1,2 | 1.75 | 1.8 | 1.95 | V |
| t_{R_VDD} | Supply rise time (0 V to VDD) | 3 | | | 50 | ms |
| T_A | Operating temperature | | -40 | 25 | 85 | °C |

1. Minimum operating temperature is -25°C in low voltage mode.
2. DEC2 shall be connected to VDD in this mode.
3. The on-chip power-on reset circuitry may not function properly for rise times outside the specified interval.

Table 18 Operating conditions

Nominal operating conditions (NOC) - conditions under which the chip is operated and tested are the typical (Typ.) values in *Table 18*.

Extreme operating conditions (EOC) - conditions under which the chip is operated and tested are the minimum (Min.) and maximum (Max.) values in *Table 18*.

8 Electrical specifications

This chapter contains electrical specifications for device interfaces and peripherals including radio parameters and current consumption.

The test levels referenced are defined in *Table 19*.

| Test level | Description |
|------------|---|
| 1 | Simulated, calculated, by design (specification limit) or prototype samples tested at NOC. |
| 2 | Parameters have been verified at Test level 1 and in addition: Prototype samples tested at EOC. |
| 3 | Parameters have been verified at Test level 2 and in addition: Production samples tested at EOC in accordance with JEDEC47. |
| 4 | Parameters have been verified at Test level 3 and in addition: Production devices are limit tested at NOC. |

Table 19 Test level definitions

8.1 Clock sources

8.1.1 16/32 MHz crystal startup

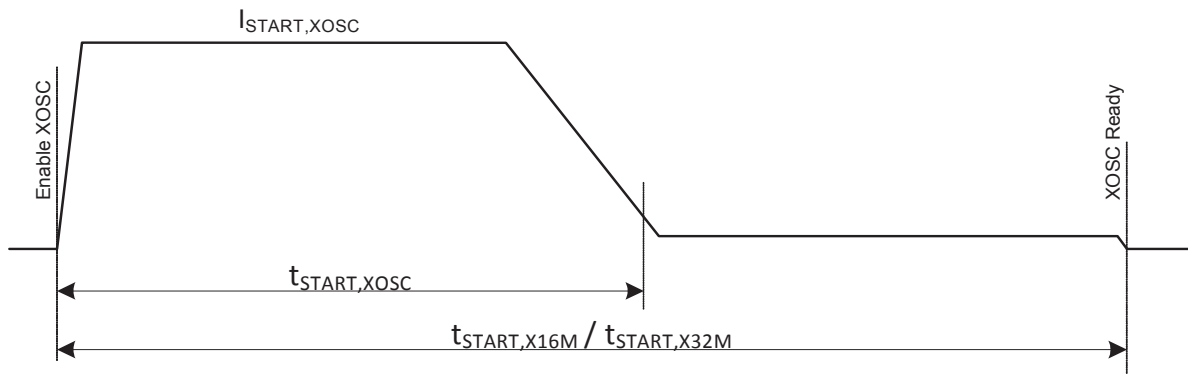

Figure 8 Current drawn at oscillator startup

Figure 8 shows the current drawn by the crystal oscillator (XOSC) at startup. The $t_{\text{START,XOSC}}$ period is the time needed for the oscillator to start clocking. The length of $t_{\text{START,XOSC}}$ is dependent on the crystal specifications.

The period following $t_{\text{START,XOSC}}$ to the end of $t_{\text{START,X16M}} / t_{\text{START,X32M}}$ is fixed. This is the debounce period where the clock stabilizes before it is made available to rest of the system.

8.1.2 16 MHz crystal oscillator (16M XOSC)

| Symbol | Description | Note | Min. | Typ. | Max. | Units | Test level |
|---------------------------|--|--|------|---------|------------|---------------|------------|
| $f_{\text{NOM},X16M}$ | Crystal frequency. | | | 16 | | MHz | N/A |
| $f_{\text{TOL},X16M}$ | Frequency tolerance. ¹ | | | | $\pm 50^2$ | ppm | N/A |
| $f_{\text{TOL},X16M,BLE}$ | Frequency tolerance, <i>Bluetooth</i> low energy applications. ¹ | | | | $\pm 40^2$ | ppm | N/A |
| $R_{S,X16M}$ | Equivalent series resistance. | $C_0 \leq 7 \text{ pF}, C_{L,\text{MAX}} \leq 16 \text{ pF}$ | | 50 | 100 | Ω | N/A |
| | | $C_0 \leq 5 \text{ pF}, C_{L,\text{MAX}} \leq 12 \text{ pF}$ | | 75 | 150 | Ω | N/A |
| | | $C_0 \leq 3 \text{ pF}, C_{L,\text{MAX}} \leq 12 \text{ pF}$ | | 100 | 200 | Ω | N/A |
| $P_{D,X16M}$ | Drive level. | | | | 100 | μW | N/A |
| C_{pin} | Input capacitance on XC1 and XC2 pads. | | | 4 | | pF | 1 |
| I_{X16M} | Run current for 16 MHz crystal oscillator. | SMD 2520 CL = 8 pF | | 350^3 | | μA | 1 |
| $I_{X16M,1M}$ | Run current for the 16 MHz crystal oscillator when used only for a Timer at 1 MHz or less. | SMD 2520 CL = 8 pF | | 250^3 | | μA | 1 |
| $I_{\text{STBY},X16M}$ | Standby current for 16 MHz crystal oscillator. ⁴ | SMD 2520 CL = 8 pF | | 25 | | μA | 1 |
| $I_{\text{START},XOSC}$ | Startup current for 16 MHz crystal oscillator. | | | 1.1 | | mA | 3 |
| $t_{\text{START},XOSC}$ | Startup time for 16 MHz crystal oscillator. | SMD 2520 CL = 8 pF | | 400 | 500^5 | μs | 2 |
| $t_{\text{START},X16M}$ | Total startup time ($t_{\text{START},XOSC}$ + debounce period). ⁶ | SMD 2520 CL = 8 pF | | 800 | | μs | 1 |
| V_{INEXTCLK} | Input amplitude if driven by external clock applied to XC1 pin. ⁷ | | 800 | | 8 | mV pp | 1 |

1. The Frequency tolerance relates to the amount of time the radio can be in transmit mode. See **Table 36** on page 47.
2. Includes initial tolerance of the crystal, drift over temperature, aging, and frequency pulling due to incorrect load capacitance.
3. This number includes the current used by the automated power and clock management system.
4. Standby current is the current drawn by the oscillator when there are no resources requesting the 16M, meaning there is no clock management active (see **Table 31** on page 44). This value will depend on type of crystal.
5. Crystals with other specification than SMD 2520 may have much longer startup times.
6. This is the time from when the crystal oscillator is powered up until its output becomes available to the system. It includes both the crystal startup time and the debounce period.
7. Leave XC2 pin unconnected.
8. Input signal must not swing outside supply rails.

Table 20 16 MHz crystal oscillator

8.1.3 32 MHz crystal oscillator (32M XOSC)

| Symbol | Description | Note | Min. | Typ. | Max. | Units | Test level |
|---|--|---|------|---------|------------|---------------|------------|
| $f_{\text{NOM},\text{X32M}}$ | Crystal frequency. | | | 32 | | MHz | N/A |
| $f_{\text{TOL},\text{X32M}}$ | Frequency tolerance. ¹ | | | | $\pm 50^2$ | ppm | N/A |
| $f_{\text{TOL},\text{X32M},\text{BLE}}$ | Frequency tolerance, <i>Bluetooth</i> low energy applications. ¹ | | | | $\pm 40^2$ | ppm | N/A |
| $R_{\text{S},\text{X32M}}$ | Equivalent series resistance. | $C_0 \leq 7 \text{ pF}, C_{\text{L},\text{MAX}} \leq 12 \text{ pF}$ | | 30 | 60 | Ω | N/A |
| | | $C_0 \leq 5 \text{ pF}, C_{\text{L},\text{MAX}} \leq 12 \text{ pF}$ | | 40 | 80 | Ω | N/A |
| | | $C_0 \leq 3 \text{ pF}, C_{\text{L},\text{MAX}} \leq 9 \text{ pF}$ | | 50 | 100 | Ω | N/A |
| $P_{\text{D},\text{X32M}}$ | Drive level. | | | | 100 | μW | N/A |
| C_{pin} | Input capacitance on XC1 and XC2 pads. | | | 4 | | pF | 1 |
| I_{X32M} | Run current for 32 MHz crystal oscillator. | SMD 2520 CL = 8 pF | | 500^3 | | μA | 1 |
| $I_{\text{X32M},1\text{M}}$ | Run current for the 32 MHz crystal oscillator when used only for a Timer at 1 MHz or less. | SMD 2520 CL = 8 pF | | 300^3 | | μA | 1 |
| $I_{\text{STBY},\text{X32M}}$ | Standby current for 32 MHz crystal oscillator. ⁴ | SMD 2520 CL = 8 pF | | 30 | | μA | 1 |
| $I_{\text{START},\text{XOSC}}$ | Startup current for 32 MHz crystal oscillator. | | | 1.1 | | mA | 3 |
| $t_{\text{START},\text{XOSC}}$ | Startup time for 32 MHz crystal oscillator. | SMD 2520 CL = 8 pF | | 300 | 400^5 | μs | 1 |
| $t_{\text{START},\text{X32M}}$ | Total startup time ($t_{\text{START},\text{XOSC}}$ + debounce period). ⁶ | SMD 2520 CL = 8 pF | | 750 | | μs | 1 |

1. The Frequency tolerance relates to the amount of time the radio can be in transmit mode. See **Table 36** on page 47.
2. Includes initial tolerance of the crystal, drift over temperature, aging and frequency pulling due to incorrect load capacitance.
3. This number includes the current used by the automated power and clock management system.
4. Standby current is the current drawn by the oscillator when there are no resources requesting the 32M, meaning there is no clock management active (see **Table 31** on page 44). This value will depend on type of crystal.
5. Crystals with other specification than SMD 2520 may have much longer startup times.
6. This is the time from when the crystal oscillator is powered up until its output becomes available to the system. It includes both the crystal startup time and the debounce period.

Table 21 32 MHz crystal oscillator

8.1.4 16 MHz RC oscillator (16M RCOSC)

| Symbol | Description | Min. | Typ. | Max. | Units | Test level |
|---------------------------|---|------|------------------|---------|---------------|------------|
| $f_{\text{NOM,RC16M}}$ | Nominal frequency. | | 16 | | MHz | N/A |
| $f_{\text{TOL,RC16M}}$ | Frequency tolerance. | | ± 1 | ± 5 | % | 3 |
| I_{RC16M} | Run current for 16 MHz RC oscillator. | | 700 ¹ | | μA | 1 |
| $I_{\text{RC16M,1M}}$ | Run current for 16 MHz RCOSC when used only for a Timer at 1 MHz or less. | | 540 ¹ | | μA | 1 |
| $t_{\text{START,RC16M}}$ | Startup time for 16 MHz RC oscillator. | | 4.2 | 5.2 | μs | 1 |
| $I_{\text{RC16M, START}}$ | Startup current for 16 MHz RC oscillator. | | 400 | | μA | 1 |

1. This number includes the current used by the automated power and clock management system.

Table 22 16 MHz RC oscillator

8.1.5 32.768 kHz crystal oscillator (32k XOSC)

| Symbol | Description | Min. | Typ. | Max. | Units | Test level |
|---------------------------|--|------|--------|--------------------|------------------|------------|
| $f_{\text{NOM,X32k}}$ | Crystal frequency. | | 32.768 | | kHz | N/A |
| $f_{\text{TOL,X32k,BLE}}$ | Frequency tolerance, <i>Bluetooth</i> low energy applications. | | | ± 250 | ppm | N/A |
| $C_{\text{L,X32k}}$ | Load capacitance. | | | 12.5 | pF | N/A |
| $C_{\text{0,X32k}}$ | Shunt capacitance. | | | 2 | pF | N/A |
| $R_{\text{S,X32k}}$ | Equivalent series resistance. | | 50 | 80 | $\text{k}\Omega$ | N/A |
| $P_{\text{D,X32k}}$ | Drive level. | | | 1 | μW | N/A |
| C_{pin} | Input capacitance on XL1 and XL2 pads. | | 4 | | pF | 1 |
| I_{X32k} | Run current for 32.768 kHz crystal oscillator. | | 0.7 | 1 | μA | 1 |
| $I_{\text{START,X32k}}$ | Startup current for 32.768 kHz crystal oscillator. | | 1.3 | 1.8 | μA | 1 |
| $t_{\text{START,X32k}}$ | Startup time for 32.768 kHz crystal oscillator. | | 0.3 | 1 | s | 2 |
| V_{INEXTCLK} | Input amplitude if driven by external clock applied to XL1 pin. ¹ | 200 | | 600 ^{2,3} | mV pp | 1 |

1. Leave XL2 pin unconnected.
2. The oscillator run current will increase above 1 μA for higher amplitudes.
3. Input signal must not swing outside supply rails.

Table 23 32.768 kHz crystal oscillator

8.1.6 32.768 kHz RC oscillator (32k RCOSC)

| Symbol | Description | Note | Min. | Typ. | Max. | Units | Test level |
|---------------------|----------------------|--------------------------|------|---------|-----------|---------|------------|
| $f_{NOM,RC32k}$ | Nominal frequency. | | | 32.768 | | kHz | N/A |
| $f_{TOL,RC32k}$ | Frequency tolerance. | | | ± 2 | | % | 3 |
| $f_{TOL,CAL,RC32k}$ | Frequency tolerance. | Calibration interval 4 s | | | ± 250 | ppm | 1 |
| I_{RC32k} | Run current. | | 0.5 | 1.3 | 1.5 | μA | 1 |
| $t_{START,RC32k}$ | Startup time. | | | 390 | 487 | μs | 1 |

Table 24 32.768 kHz RC oscillator

8.1.7 32.768 kHz Synthesized oscillator (32k SYNT)

| Symbol | Description | Note | Min. | Typ. | Max. | Units | Test level |
|---------------------|--|------|------|--|------|---------|------------|
| $f_{NOM,SYNT32k}$ | Nominal frequency. | | | 32.768 | | kHz | 1 |
| $f_{TOL,SYNT}$ | Frequency tolerance. | | | $f_{TOL,XO16M} \pm 8$ $f_{TOL,XO32M} \pm 8$ | | ppm | 1 |
| $I_{SYNT32k}$ | Run and startup current for 32.768 kHz Synthesized clock including the 16M XOSC. | | | 15 | | μA | 1 |
| $t_{START,SYNT32k}$ | Startup time for 32.768 kHz Synthesized clock. | | | 406 | | μs | 1 |

Table 25 32.768 kHz Synthesized oscillator

8.2 Power management

| Symbol | Description | Note | Min. | Typ. | Max. | Units | Test level |
|------------|--|--|------|--------------------------|------|-------|------------|
| V_{POF} | Nominal power level warning thresholds (falling supply voltage). | Accuracy as defined by V_{TOL} | | 2.1 2.3 2.5 2.7 | | V | 2 |
| V_{TOL} | Threshold voltage tolerance. | | | | ±5 | % | 3 |
| V_{HYST} | Threshold voltage hysteresis. | $V_{POF} = 2.1\text{ V}$ $V_{POF} = 2.3\text{ V}$ $V_{POF} = 2.5\text{ V}$ $V_{POF} = 2.7\text{ V}$ | | 46 62 79 100 | | mV | 3 |

Table 26 Power Fail Comparator

| Symbol | Description | Min. | Typ. | Max. | Units | Test level |
|-----------------------|---|------|------|------|-------|------------|
| $t_{HOLDRESETNORMAL}$ | Hold time for reset pin when doing a pin reset. ¹ | 0.2 | | | µs | 1 |
| $t_{HOLDRESETDEBUG}$ | Hold time for reset pin when doing a pin reset during debug. ^{1,2} | 100 | | | µs | 1 |

1. SWDCLK pin must be kept low during reset.
2. Bit 0 in the RESET register in the power management module must be set to 1 to enable reset during debug.

Table 27 Pin Reset

Power on reset time (t_{POR}) is the time from when the supply starts rising to when the device comes out of reset and the CPU starts. The time increases with, and is inclusive of, supply rise time from 0 V to VDD. **Table 28** gives t_{POR} for a number of supply rise times, simulated with a linear ramp from 0 V to VDD, over the supply voltage range 1.8 V to 3.6 V.

| Symbol | Description | Note | Min. | Typ. | Max. | Units | Test level |
|---------------------|---|------|------|------|------|-------|------------|
| $t_{POR, 10 \mu s}$ | Power on reset time, 10 μs rise time (0 V to VDD). | | 0.6 | 3.2 | 20 | ms | 1 |
| $t_{POR, 1 ms}$ | Power on reset time, 1 ms rise time (0 V to VDD). | | 1.5 | 4.1 | 21 | ms | 1 |
| $t_{POR, 10 ms}$ | Power on reset time, 10 ms rise time (0 V to VDD). | | 10 | 13 | 30 | ms | 1 |
| $t_{POR, 50 ms}$ | Power on reset time, 50 ms rise time (0 V to VDD). | | 38 | 52 | 68 | ms | 1 |

Table 28 Power on reset time

The data in **Figure 9** and **Table 29** show measured t_{POR} data. Measurements were taken using the reference circuit shown in **Section 11.3.1 “QFAA QFN48 schematic with internal LDO setup”** on page 73 with the given supply voltage and temperature conditions.

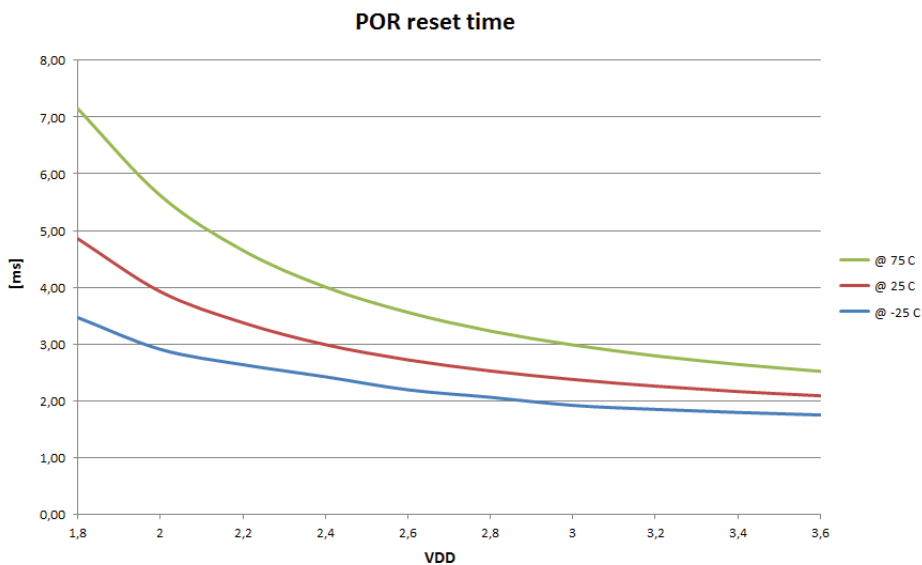

Figure 9 Power on reset time (Test level 2)

| VDD | Rise Time from 10% to 90% of VDD |
|-----|----------------------------------|
| 1.8 | 570 μs |
| 3.0 | 605 μs |
| 3.6 | 635 μs |

Table 29 Supply rise time at sample voltages for the measured data shown in **Figure 9**.

| Symbol | Description | Note | Min. | Typ. | Max. | Units | Test level |
|------------------|---|---------------------------------|------|------------------|------|---------------|------------|
| I_{OFF} | Current in SYSTEM OFF, no RAM retention. | | | 0.6 ¹ | | μA | 2 |
| $I_{OFF,RET,8k}$ | Additional current in SYSTEM OFF per retained RAM block (8 kB) | | | 0.6 ¹ | | μA | 2 |
| I_{OFF2ON} | OFF to CPU execute transition current. | | | 400 | | μA | 1 |
| t_{OFF2ON} | OFF to CPU execute. | | 13.1 | 14.1 | | μs | 1 |
| $I_{ON,16k}$ | SYSTEM-ON base current with 16 kB RAM enabled. | | | 3 ¹ | | μA | 2 |
| t_{1V2} | Startup time for 1V2 regulator. | | | 2.3 | | μs | 1 |
| $I_{1V2XO16}$ | Current drawn by 1V2 regulator and 16 MHz XOSC when both are on at the same time. | See Table 31 on page 44. | | 810 ² | | μA | 1 |
| $I_{1V2XO32}$ | Current drawn by 1V2 regulator and 32 MHz XOSC when both are on at the same time. | See Table 31 on page 44. | | 840 ² | | μA | 1 |
| $I_{1V2RC16}$ | Current drawn by 1V2 regulator and 16 MHz RCOSC when both are on at the same time. | See Table 31 on page 44. | | 880 ² | | μA | 1 |
| $I_{1V2XO16,1M}$ | For HFCLK in 1 MHz mode ³ . Current drawn by 1V2 regulator and 16 MHz XOSC when both are on at the same time. | See Table 31 on page 44. | | 520 ² | | μA | 1 |
| $I_{1V2XO32,1M}$ | For HFCLK in 1 MHz mode ³ . Current drawn by 1V2 regulator and 32 MHz XOSC when both are on at the same time. | See Table 31 on page 44. | | 560 ² | | μA | 1 |
| $I_{1V2RC16,1M}$ | For HFCLK in 1 MHz mode ³ . Current drawn by 1V2 regulator and 16 MHz RCOSC when both are on at the same time. | See Table 31 on page 44. | | 630 ² | | μA | 1 |
| t_{XO} | Startup time for the clock management system when the XTAL is in standby. | | | 2.3 | 5.3 | μs | 1 |

| Symbol | Description | Note | Min. | Typ. | Max. | Units | Test level |
|-------------------|--|------|-------------------|------|------------------|---------------|------------|
| t_{1V7} | Startup time for 1V7 regulator | | | 2 | 3.6 | μs | 1 |
| I_{1V7} | Current drawn by 1V7 regulator | | | 275 | | μA | 2 |
| F_{DCDC} | DC/DC converter current conversion factor. | | 0.65 ⁴ | | 1.2 ⁴ | | 1 |

1. Add 1 μA to the current value if the device is used in Low voltage mode.
2. This number includes the current used by the automated power and clock management system.
3. For details on 1 MHz mode, see **Section 4.2 "Timer/counters (TIMER)"** on page 28.
4. F_{DCDC} will vary depending on VDD and internal radio current consumption (I_{DD}). Please refer to the *nRF51 Series Reference Manual*, v3.0 or later, for a method to calculate $I_{\text{DD,DCDC}}$. See **Figure 10** on page 46 for a DC/DC conversion factor chart.

Table 30 Power management

8.3 Block resource requirements

| Block | ID | Resource requirements | | | | Comment |
|--------|----------|-----------------------|--------------------|-------|-----|---|
| | | 1V2 | HFCLK ¹ | LFCLK | 1V7 | |
| Radio | 1 | x | x | | | Requires HFCLK XOSC. |
| UART | 2 | x | x | | | When receiver or transmitter are STARTed. |
| SPIS | 4 | x | x | | | Requested when CSN asserts. |
| SPI | 3, 4 | x | x | | | |
| TWI | 3, 4 | x | x | | | |
| GPIOTE | 6 | x | x | | | Only in input mode. |
| ADC | 7 | x | x | | | Requires HFCLK XOSC. |
| TIMER | 8, 9, 10 | | x | | | Requires 1V2 when a TIMER EVENT is triggered. |
| RTC | 11, 17 | | | x | | HFCLK will be requested if the LFCLK is synthesized from HFCLK. |
| TEMP | 12 | x | x | | | Requires HFCLK XOSC. |
| RNG | 13 | x | x | | | |
| ECB | 14 | x | x | | | |
| WDT | 16 | | | x | | HFCLK will be requested if the LFCLK is synthesized from HFCLK. |
| QDEC | 18 | x | x | | | |
| LPCOMP | 19 | | | | | No resources required. |
| CPU | -- | x | x | | x | |

1. HFCLK could be one of the following; RC16M, XO16M, or XO32M.

Table 31 Clock and power requirements for different blocks

8.4 CPU

| Symbol | Description | Min. | Typ. | Max. | Units | Test level |
|-------------------------|--|------------------|------------------|------|---------------|------------|
| $I_{\text{CPU, FLASH}}$ | Run current at 16 MHz (XOSC). Executing code from flash memory. | | 4.1 ¹ | | mA | 2 |
| $I_{\text{CPU, RAM}}$ | Run current at 16 MHz (XOSC). Executing code from RAM. | | 2.4 ² | | mA | 1 |
| $I_{\text{START, CPU}}$ | CPU startup current. | | 600 | | μA | 1 |
| $t_{\text{START, CPU}}$ | IDLE to CPU execute. | 3.5 ³ | | | μs | 1 |

1. Includes CPU, flash, 1V2, 1V7, RC16M.
2. Includes CPU, RAM, 1V2, RC16M.
3. t_{1V2} must be added if the 1V2 regulator is not running already.

Table 32 CPU specifications

8.5 Radio transceiver

8.5.1 General radio characteristics

| Symbol | Description | Note | Min. | Typ. | Max. | Units | Test level |
|------------------|----------------------------------|------------------------|-----------|-----------|-----------|-------|------------|
| f_{OP} | Operating frequencies. | 1 MHz channel spacing. | 2400 | | 2483 | MHz | N/A |
| PLL_{res} | PLL programming resolution. | | | 1 | | MHz | N/A |
| Δf_{250} | Frequency deviation at 250 kbps. | | | ± 170 | | kHz | 2 |
| Δf_{1M} | Frequency deviation at 1 Mbps. | | | ± 170 | | kHz | 2 |
| Δf_{2M} | Frequency deviation at 2 Mbps. | | | ± 320 | | kHz | 2 |
| Δf_{BLE} | Frequency deviation at BLE. | | ± 225 | ± 250 | ± 275 | kHz | 4 |
| bps_{FSK} | On-air data rate. | | 250 | | 2000 | kbps | N/A |

Table 33 General radio characteristics

8.5.2 Radio current consumption with DC/DC disabled

| Symbol | Description | Note | Min. | Typ. | Max. | Units | Test level |
|-----------------|---|------|------|------|------|-------|------------|
| $I_{TX,+4dBm}$ | TX only run current at $P_{OUT} = +4$ dBm. | 1 | | 16 | | mA | 4 |
| $I_{TX,0dBm}$ | TX only run current at $P_{OUT} = 0$ dBm. | 1 | | 10.5 | | mA | 4 |
| $I_{TX,-4dBm}$ | TX only run current at $P_{OUT} = -4$ dBm. | 1 | | 8 | | mA | 2 |
| $I_{TX,-8dBm}$ | TX only run current at $P_{OUT} = -8$ dBm. | 1 | | 7 | | mA | 2 |
| $I_{TX,-12dBm}$ | TX only run current at $P_{OUT} = -12$ dBm. | 1 | | 6.5 | | mA | 2 |
| $I_{TX,-16dBm}$ | TX only run current at $P_{OUT} = -16$ dBm. | 1 | | 6 | | mA | 2 |
| $I_{TX,-20dBm}$ | TX only run current at $P_{OUT} = -20$ dBm. | 1 | | 5.5 | | mA | 2 |
| $I_{TX,-30dBm}$ | TX only run current at $P_{OUT} = -30$ dBm. | 1 | | 5.5 | | mA | 2 |
| $I_{START,TX}$ | TX startup current. | 2 | | 7 | | mA | 1 |
| $I_{RX,250}$ | RX only run current at 250 kbps. | | | 12.6 | | mA | 1 |
| $I_{RX,1M}$ | RX only run current at 1 Mbps. | | | 13 | | mA | 4 |
| $I_{RX,2M}$ | RX only run current at 2 Mbps. | | | 13.4 | | mA | 1 |
| $I_{START,RX}$ | RX startup current. | 3 | | 8.7 | | mA | 1 |

1. Valid for data rates 250 kbps, 1 Mbps, and 2 Mbps.
2. Average current consumption (at 0 dBm TX output power) for TX startup (130 μ s), and when changing mode from RX to TX (130 μ s).
3. Average current consumption for RX startup (130 μ s), and when changing mode from TX to RX (130 μ s).

Table 34 Radio current consumption with DC/DC disabled (NOC, $V_{DD} = 3$ V)

8.5.3 Radio current consumption with DC/DC enabled

| Symbol | Description | Note | Min. | Typ. | Max. | Units | Test level |
|-----------------|---|------|------|------|------|-------|------------|
| $I_{TX,+4dBm}$ | TX only run current at $P_{OUT} = +4$ dBm. | 1 | | 11.8 | | mA | 2 |
| $I_{TX,0dBm}$ | TX only run current at $P_{OUT} = 0$ dBm. | 1 | | 8.0 | | mA | 2 |
| $I_{TX,-4dBm}$ | TX only run current at $P_{OUT} = -4$ dBm. | 1 | | 6.3 | | mA | 2 |
| $I_{TX,-8dBm}$ | TX only run current at $P_{OUT} = -8$ dBm. | 1 | | 5.6 | | mA | 2 |
| $I_{TX,-12dBm}$ | TX only run current at $P_{OUT} = -12$ dBm. | 1 | | 5.3 | | mA | 2 |
| $I_{TX,-16dBm}$ | TX only run current at $P_{OUT} = -16$ dBm. | 1 | | 5.0 | | mA | 2 |
| $I_{TX,-20dBm}$ | TX only run current at $P_{OUT} = -20$ dBm. | 1 | | 4.7 | | mA | 2 |
| $I_{TX,-30dBm}$ | TX only run current at $P_{OUT} = -30$ dBm. | 1 | | 4.7 | | mA | 2 |
| $I_{RX,1M}$ | RX only run current at 1 Mbps. | | | 10.0 | | mA | 2 |

1. Valid for data rates 250 kbps, 1 Mbps, and 2 Mbps.

Table 35 Radio current consumption with DC/DC enabled (NOC, VDD = 3 V)

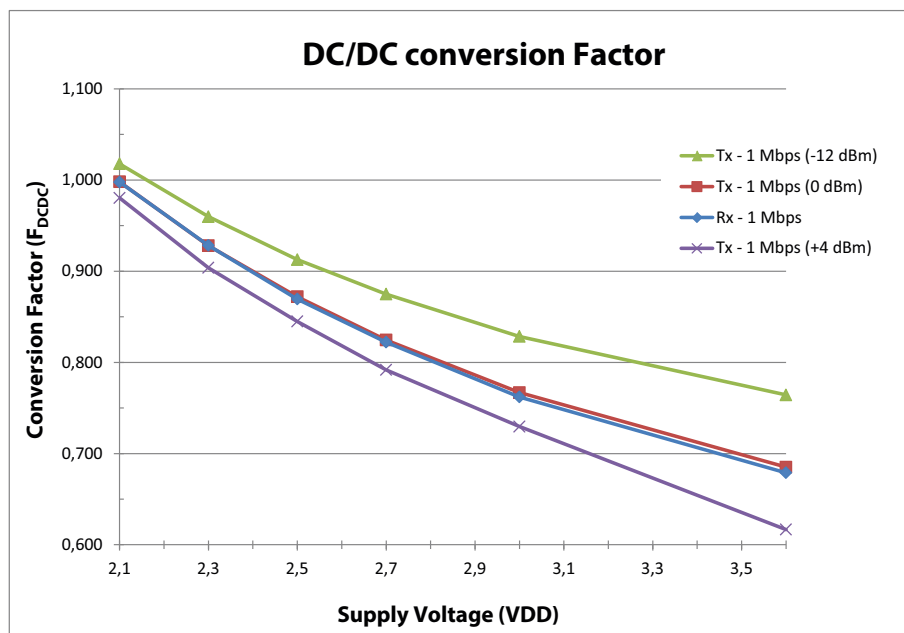

Figure 10 DC/DC conversion factor as function of VDD

See Power chapter in the *nRF51 Series Reference Manual* on how to use the DC/DC conversion factor to calculate the actual power consumption.

8.5.4 Transmitter specifications

| Symbol | Description | Min. | Typ. | Max. | Units | Test level |
|---------------|---|------|------|---------|-------|------------|
| P_{RF} | Maximum output power. | | 4 | | dBm | 4 |
| P_{RFC} | RF power control range. | 20 | 24 | | dB | 2 |
| PRFCR | RF power accuracy. | | | ± 4 | dB | 1 |
| P_{WHISP} | RF power whisper mode. | | -35 | | dBm | 2 |
| P_{BW2} | 20 dB bandwidth for modulated carrier (2 Mbps). | | 1800 | 2000 | kHz | 2 |
| P_{BW1} | 20 dB bandwidth for modulated carrier (1 Mbps). | | 950 | 1200 | kHz | 2 |
| P_{BW250} | 20 dB bandwidth for modulated carrier (250 kbps). | | 700 | 800 | kHz | 2 |
| $P_{RF1.2}$ | 1 st Adjacent Channel Transmit Power. ± 2 MHz (2 Mbps). | | | -20 | dBc | 2 |
| $P_{RF2.2}$ | 2 nd Adjacent Channel Transmit Power. ± 4 MHz (2 Mbps). | | | -45 | dBc | 2 |
| $P_{RF1.1}$ | 1 st Adjacent Channel Transmit Power. ± 1 MHz (1 Mbps). | | | -20 | dBc | 2 |
| $P_{RF2.1}$ | 2 nd Adjacent Channel Transmit Power. ± 2 MHz (1 Mbps). | | | -40 | dBc | 2 |
| $P_{RF1.250}$ | 1 st Adjacent Channel Transmit Power. ± 1 MHz (250 kbps). | | | -25 | dBc | 2 |
| $P_{RF2.250}$ | 2 nd Adjacent Channel Transmit Power. ± 2 MHz (250 kbps). | | | -40 | dBc | 2 |
| $t_{TX,30}$ | Maximum consecutive transmission time, $f_{TOL} < \pm 30$ ppm. | | | 16 | ms | 1 |
| $t_{TX,60}$ | Maximum consecutive transmission time, $f_{TOL} < \pm 60$ ppm. | | | 4 | ms | 1 |

Table 36 Transmitter specifications

8.5.5 Receiver specifications

| Symbol | Description | Min. | Typ. | Max. | Units | Test level |
|--|---|------|------|------|-------|------------|
| Receiver operation | | | | | | |
| PRX _{MAX} | Maximum received signal strength at < 0.1% PER. | | 0 | | dBm | 1 |
| PRX _{SENS,2M} | Sensitivity (0.1% BER) at 2 Mbps. | | -83 | | dBm | 2 |
| PRX _{SENS,1M} | Sensitivity (0.1% BER) at 1 Mbps. | | -88 | | dBm | 2 |
| PRX _{SENS,250k} | Sensitivity (0.1% BER) at 250 kbps. | | -94 | | dBm | 2 |
| P _{SENS IT} 1 Mbps BLE | Receiver sensitivity: Ideal transmitter. | | -91 | | dBm | 2 |
| P _{SENS DT} 1 Mbps BLE | Receiver sensitivity: Dirty transmitter. ¹ | | -89 | | dBm | 2 |
| RX selectivity - modulated interfering signal² | | | | | | |
| 2 Mbps | | | | | | |
| C/I _{CO} | C/I co-channel. | | 14 | | dB | 2 |
| C/I _{1ST} | 1 st ACS, C/I 2 MHz. | | 0 | | dB | 2 |
| C/I _{2ND} | 2 nd ACS, C/I 4 MHz. | | -22 | | dB | 2 |
| C/I _{3RD} | 3 rd ACS, C/I 6 MHz. | | -28 | | dB | 2 |
| C/I _{6th} | 6 th ACS, C/I 12 MHz. | | -42 | | dB | 2 |
| C/I _{Nth} | N th ACS, C/I f _i > 25 MHz. | | -48 | | dB | 2 |
| 1 Mbps | | | | | | |
| C/I _{CO} | C/I co-channel (1 Mbps). | | 12 | | dB | 2 |
| C/I _{1ST} | 1 st ACS, C/I 1 MHz. | | 4 | | dB | 2 |
| C/I _{2ND} | 2 nd ACS, C/I 2 MHz. | | -24 | | dB | 2 |
| C/I _{3RD} | 3 rd ACS, C/I 3 MHz. | | -30 | | dB | 2 |
| C/I _{6th} | 6 th ACS, C/I 6 MHz. | | -40 | | dB | 2 |
| C/I _{12th} | 12 th ACS, C/I 12 MHz. | | -46 | | dB | 2 |
| C/I _{Nth} | N th ACS, C/I f _i > 25 MHz. | | -51 | | dB | 2 |

| Symbol | Description | Min. | Typ. | Max. | Units | Test level |
|--|--|------|------|------|-------|------------|
| 250 kbps | | | | | | |
| C/I _{CO} | C/I co-channel. | | 4 | | dB | 2 |
| C/I _{1ST} | 1 st ACS, C/I 1 MHz. | | -10 | | dB | 2 |
| C/I _{2ND} | 2 nd ACS, C/I 2 MHz. | | -33 | | dB | 2 |
| C/I _{3RD} | 3 rd ACS, C/I 3 MHz. | | -37 | | dB | 2 |
| C/I _{6th} | 6 th ACS, C/I f _i > 6 MHz. | | -50 | | dB | 2 |
| C/I _{12th} | 12 th ACS, C/I 12 MHz. | | -55 | | dB | 2 |
| C/I _{Nth} | N th ACS, C/I f _i > 25 MHz. | | -58 | | dB | 2 |
| Bluetooth Low Energy RX selectivity | | | | | | |
| C/I _{CO} | C/I co-channel. | | 12 | | dB | 2 |
| C/I _{1ST} | 1 st ACS, C/I 1 MHz. | | 3 | | dB | 2 |
| C/I _{2ND} | 2 nd ACS, C/I 2 MHz. | | -25 | | dB | 2 |
| C/I _{3+N} | ACS, C/I (3+n) MHz offset [n = 0, 1, 2, ...]. | | -51 | | dB | 2 |
| C/I _{Image} | Image blocking level. | | -30 | | dB | 2 |
| C/I _{Image±1MHz} | Adjacent channel to image blocking level (±1 MHz). | | -31 | | dB | 2 |
| RX intermodulation³ | | | | | | |
| P_IMD _{2Mbps} | IMD performance, 2 Mbps, 3rd, 4th, and 5th offset channel. | | -37 | | dBm | 2 |
| P_IMD _{1Mbps} | IMD performance, 1 Mbps, 3rd, 4th, and 5th offset channel. | | -36 | | dBm | 2 |
| P_IMD _{250kbps} | IMD performance, 250 kbps, 3rd, 4th, and 5th offset channel. | | -33 | | dBm | 2 |
| P_IMD _{BLE} | IMD performance, 1 Mbps BLE, 3rd, 4th, and 5th offset channel. | | -38 | | dBm | 2 |

1. As defined in the *Bluetooth Core Specification v4.0 Volume 6: Core System Package (Low Energy Controller Volume)*.
2. Wanted signal level at P_{IN} = -67 dBm. One interferer is used, having equal modulation as the wanted signal. The input power of the interferer where the sensitivity equals BER = 0.1% is presented.
3. Wanted signal level at P_{IN} = -64 dBm. Two interferers with equal input power are used. The interferer closest in frequency is not modulated, the other interferer is modulated equal with the wanted signal. The input power of interferers where the sensitivity equals BER = 0.1% is presented.

Table 37 Receiver specifications

8.5.6 Radio timing parameters

| Symbol | Description | 250 k | 1 M | 2 M | BLE | Jitter | Units |
|-----------------|--|-------|-----|-----|-----|--------|---------|
| t_{TXEN} | Time between TXEN task and READY event. | 132 | 132 | 132 | 140 | 0 | μs |
| $t_{TXDISABLE}$ | Time between DISABLE task and DISABLED event when the radio was in TX. | 10 | 4 | 3 | 4 | 1 | μs |
| t_{RXEN} | Time between the RXEN task and READY event. | 130 | 130 | 130 | 138 | 0 | μs |
| $t_{RXDISABLE}$ | Time between DISABLE task and DISABLED event when the radio was in RX. | 0 | 0 | 0 | 0 | 1 | μs |
| $t_{TXCHAIN}$ | TX chain delay. | 5 | 1 | 0.5 | 1 | 0 | μs |
| $t_{RXCHAIN}$ | RX chain delay. | 12.5 | 3 | 2 | 3 | 0 | μs |

Table 38 Radio timing

8.5.7 Antenna matching network requirements

| Symbol | Description | Min. | Typ. | Max. | Units | Test level |
|--------------------|---|------|-------------|------|----------|------------|
| $Z_{QFN48,ANT1,2}$ | Optimum differential impedance at 2.4 GHz seen into the matching network from pin ANT1 and ANT2 on the QFN48 package. | | $20 + j88$ | | Ω | 1 |
| $Z_{QFN32,ANT1,2}$ | Optimum differential impedance at 2.4 GHz seen into the matching network from pin ANT1 and ANT2 on the QFN32 package. | | $16 + j102$ | | Ω | 1 |

Table 39 Optimum differential load impedance

8.6 Received Signal Strength Indicator (RSSI) specifications

| Symbol | Description | Note | Min. | Typ. | Max. | Units | Test level |
|---------------------|---|---------------------------------|------|------|---------|---------|------------|
| $RSSI_{ACC}$ | RSSI accuracy. | Valid range -50 dBm to -80 dBm. | | | ± 6 | dB | 2 |
| $RSSI_{RESOLUTION}$ | RSSI resolution. | | | 1 | | dB | 1 |
| $RSSI_{PERIOD}$ | Sample period. | | 8.8 | | | μs | 1 |
| $RSSI_{CURRENT}$ | Current consumption in addition to I_{RX} . | | | 250 | | μA | 1 |

Table 40 RSSI specifications

8.7 Universal Asynchronous Receiver/Transmitter (UART) specifications

| Symbol | Description | Note | Min. | Typ. | Max. | Units | Test level |
|-----------------------|-------------------------------|------|------|------|------|---------------|------------|
| I_{UART1M} | Run current at max baud rate. | | | 230 | | μA | 1 |
| I_{UART115k} | Run current at 115200 bps. | | | 220 | | μA | 1 |
| I_{UART1k2} | Run current at 1200 bps. | | | 210 | | μA | 1 |
| f_{UART} | Baud rate for UART. | | 1.2 | | 1000 | kbps | N/A |
| t_{CTSH} | CTS high time. | | 1 | | | μs | 1 |

Table 41 UART specifications

8.8 Serial Peripheral Interface Slave (SPIS) specifications

| Symbol | Description | Min. | Typ. | Max. | Units | Test level |
|----------------|---|-------|------|----------------|---------------|------------|
| $I_{SPIS125K}$ | Run current for SPI slave at 125 kbps. ¹ | | 180 | | μA | 1 |
| I_{SPIS2M} | Run current for SPI slave at 2 Mbps. ¹ | | 183 | | μA | 1 |
| f_{SPIS} | Bit rates for SPIS. | 0.125 | | 4 ² | Mbps | N/A |

1. CSN asserted.
2. This bit rate is only possible if the instructions are followed in *Section 4.10.1 "Enable 4 Mbps SPIS bit rate"* on page 30.

Table 42 SPIS specifications

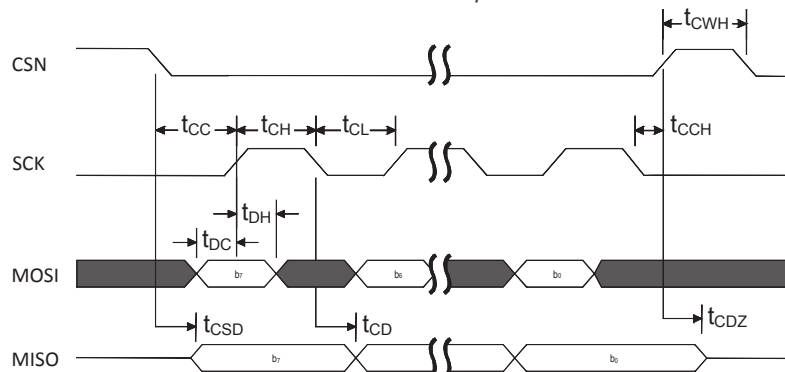

Figure 11 SPIS timing diagram, one byte transmission, SPI Mode 0

| Symbol | Description | Note | Min. | Typ. | Max. | Units | Test level |
|------------|----------------------------|---|--------------|------|-----------------|-------|------------|
| t_{DC} | Data to SCK setup. | | 10 | | | ns | 1 |
| t_{DH} | SCK to Data hold. | | 10 | | | ns | 1 |
| t_{CSD} | CSN to Data valid. | Low power mode. ¹ Constant latency mode. ¹ | | | 7100 2100 | ns | 1 |
| t_{CD} | SCK to Data Valid. | $C_{LOAD} = 10 \text{ pF}$ | | | 97 ² | ns | 1 |
| t_{CL} | SCK Low time. | | 40 | | | ns | 1 |
| t_{CH} | SCK High time. | | 40 | | | ns | 1 |
| t_{CC} | CSN to SCK Setup. | Low power mode. ¹ Constant latency mode. ¹ | 7000 2000 | | | ns | 1 |
| t_{CCH} | Last SCK edge to CSN Hold. | | 2000 | | | ns | 1 |
| t_{CWH} | CSN Inactive time. | | 300 | | | ns | 1 |
| t_{CDZ} | CSN to Output High Z. | | | | 40 | ns | 1 |
| f_{SCK} | SCK frequency. | | 0.125 | | 2 | MHz | 1 |
| t_R, t_F | SCK Rise and Fall time. | | | | 100 | ns | 1 |

1. For more information on how to control the sub power modes, see the *nRF51 Series Reference Manual*.
2. Increases/decreases with 1.2 ns/pF load.

Table 43 SPIS timing parameters

8.9 Serial Peripheral Interface (SPI) Master specifications

| Symbol | Description | Min. | Typ. | Max. | Units | Test level |
|---------------|---|-------|------|------|---------|------------|
| $I_{SPI125K}$ | Run current for SPI master at 125 kbps. | | 180 | | μA | 1 |
| I_{SPI4M} | Run current for SPI master at 4 Mbps. | | 200 | | μA | 1 |
| f_{SPI} | Bit rates for SPI. | 0.125 | | 4 | Mbps | N/A |

Table 44 SPI specifications

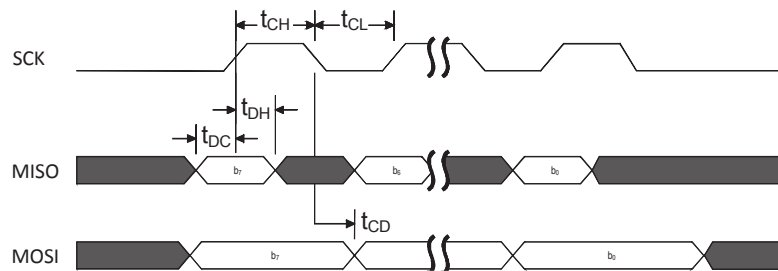

Figure 12 SPI timing diagram, one byte transmission, SPI mode 0

| Symbol | Description | Note | Min. | Typ. | Max. | Units | Test level |
|------------|-------------------------|----------------------------|-------|------|-----------------|-------|------------|
| t_{DC} | Data to SCK setup. | | 10 | | | ns | 1 |
| t_{DH} | SCK to Data hold. | | 10 | | | ns | 1 |
| t_{CD} | SCK to Data valid. | $C_{LOAD} = 10 \text{ pF}$ | | | 97 ¹ | ns | 1 |
| t_{CL} | SCK Low time. | | 40 | | | ns | 1 |
| t_{CH} | SCK High time. | | 40 | | | ns | 1 |
| f_{SCK} | SCK Frequency. | | 0.125 | | 4 | MHz | 1 |
| t_R, t_F | SCK Rise and Fall time. | | | | 100 | ns | 1 |

1. Increases/decreases with 1.2 ns/pF load.

Table 45 SPI timing parameters

8.10 I2C compatible Two Wire Interface (TWI) specifications

| Symbol | Description | Note | Min. | Typ. | Max. | Units | Test level |
|-----------------|--|---|------|--------|------|---------------|------------|
| I_{2W100K} | Run current for TWI at 100 kbps. | | | 380 | | μA | 1 |
| I_{2W400K} | Run current for TWI at 400 kbps. | | | 400 | | μA | 1 |
| f_{2W} | Bit rates for TWI. | | 100 | | 400 | kbps | N/A |
| $t_{TWI,START}$ | Time from STARTRX/STARTTX task is given until start condition. | Low power mode. ¹ Constant latency mode. ¹ | | 3 1 | 4.4 | μs | 1 |

1. For more information on how to control the sub power modes, see the *nRF51 Series Reference Manual*.

Table 46 TWI specifications

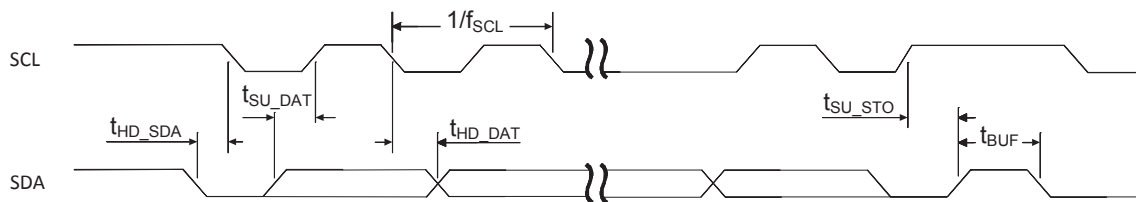

Figure 13 SCL/SDA timing

| Symbol | Description | Standard | | Fast | | Units | Test level |
|---------------|---|----------|------|------|------|-------|------------|
| | | Min. | Max. | Min. | Max. | | |
| f_{SCL} | SCL clock frequency. | | 100 | | 400 | kHz | 1 |
| t_{HD_STA} | Hold time for START and repeated START condition. | 5200 | | 1300 | | ns | 1 |
| t_{SU_DAT} | Data setup time before positive edge on SCL. | 300 | | 300 | | ns | 1 |
| t_{HD_DAT} | Data hold time after negative edge on SCL. | 300 | | 300 | | ns | 1 |
| t_{SU_STO} | Setup time from SCL goes high to STOP condition. | 5200 | | 1300 | | ns | 1 |
| t_{BUF} | Bus free time between STOP and START conditions. | 4700 | | 1300 | | ns | 1 |

Table 47 TWI timing parameters

8.11 GPIO Tasks and Events (GPIOTE) specifications

| Symbol | Description | Min. | Typ. | Max. | Units | Test level |
|--------------------------|---|------|------|------|---------------|------------|
| $I_{\text{GPIOTE,IN}}$ | Run current with 1 or more GPIOTE active channels in Input mode. | | 22 | | μA | 1 |
| $I_{\text{GPIOTE,OUT}}$ | Run current with 1 or more GPIOTE active channels in Output mode. | | 0.1 | | μA | 1 |
| $I_{\text{GPIOTE,IDLE}}$ | Run current when all channels in Idle mode. PORT event can be generated with a delay of up to t_{1V2} . | | 0.1 | | μA | 1 |

Table 48 GPIOTE specifications

Note: Setting up one or more GPIO DETECT signals to generate PORT EVENT, which can be used either as a wakeup source or to give an interrupt, will not lead to an increase of the current consumption.

8.12 Analog to Digital Converter (ADC) specifications

Note: HFCLK XOSC is required to get the stated ADC accuracy.

| Symbol | Description | Note | Min. | Typ. | Max. | Units | Test level |
|-----------------------------|--|------|------|--------|------|--------|------------|
| DNL _{10b} | Differential non-linearity (10 bit mode). | | | < 1 | | LSB | 2 |
| INL _{10b} | Integral non-linearity (10 bit mode). | | | 2 | | LSB | 2 |
| V _{OS} | Offset error. | | -2 | | +2 | % | 2 |
| e _G | Gain error. | 1 | -2 | | +2 | % | 2 |
| V _{REF_VBG} | Internal Band Gap reference voltage (VBG). | | | 1.20 V | | V | 2 |
| V _{REF_VBG_ERR} | Internal Band Gap reference voltage error. | | -1.5 | | +1.5 | % | 2 |
| TC _{REF_VBG_DRIFT} | Internal Band Gap reference voltage drift. | | -200 | | +200 | ppm/°C | 2 |
| V _{REF_EXT} | External reference voltage (AREF0/1). | | 0.83 | 1.2 | 1.3 | V | 1 |
| V _{REF_VDD_LIM} | Limited supply voltage range for ADC using VDD with prescaler as the reference. CONFIG.REFSEL = SupplyOneHalfPrescaling | | 1.75 | | 2.6 | V | 1 |
| | | | 2.5 | | 3.6 | V | 1 |
| t _{ADC10b} | Time required to convert a single sample in 10 bit mode. | | | 68 | | μs | 1 |
| t _{ADC9b} | Time required to convert a single sample in 9 bit mode. | | | 36 | | μs | 1 |
| t _{ADC8b} | Time required to convert a single sample in 8 bit mode. | | | 20 | | μs | 1 |
| I _{ADC} | Current drawn by ADC during conversion. | | | 260 | | μA | 1 |
| ADC_ERR_1V8 | | | | 3 | | LSB | 2 |
| ADC_ERR_2V2 | Absolute error when used for battery measurement at 1.8 V, 2.2 V, 2.6 V, 3.0 V, and 3.4 V. | | | 2 | | LSB | 2 |
| ADC_ERR_2V6 | | 2 | | 1 | | LSB | 2 |
| ADC_ERR_3V0 | | | | 1 | | LSB | 2 |
| ADC_ERR_3V4 | | | | 1 | | LSB | 2 |

1. Source impedance less than 5 kΩ.
2. Internal reference, input from VDD/3, 10 bit mode.

Table 49 Analog to Digital Converter (ADC) specifications

8.13 Timer (TIMER) specifications

| Symbol | Description | Note | Min. | Typ. | Max. | Units | Test level |
|----------------------------|--|------|------|------|------|---------------|------------|
| $I_{\text{TIMER0/1/2}}$ | Timer current when running from HFCLK in 16 MHz mode. | | | 30 | | μA | 1 |
| $I_{\text{TIMER0/1/2,1M}}$ | Timer current when running from HFCLK in 1 MHz mode. | | | 4 | | μA | 1 |
| $t_{\text{TIMER,START}}$ | Time from START task is given until timer starts counting. | | | 0.25 | | μs | 1 |

Table 50 Timer specifications

8.14 Real Time Counter (RTC)

| Symbol | Description | Min. | Typ. | Max. | Units | Test level |
|------------------|-----------------------|------|------|------|---------------|------------|
| I_{RTC} | Timer (LFCLK source). | | 0.1 | | μA | 1 |

Table 51 RTC

8.15 Temperature sensor (TEMP)

Note: HFCLK XOSC is required to get the stated accuracy.

| Symbol | Description | Min. | Typ. | Max. | Units | Test level |
|--------------------|--|------|------|------|--------------------|------------|
| I_{TEMP} | Run current for Temperature sensor. | | 185 | | μA | 1 |
| t_{TEMP} | Time required for temperature measurement. | | 35 | | μs | 1 |
| T_{RANGE} | Temperature sensor range. | -40 | | 85 | $^{\circ}\text{C}$ | N/A |
| T_{ACC} | Temperature sensor accuracy. ¹ | -4 | | +4 | $^{\circ}\text{C}$ | N/A |
| T_{RES} | Temperature sensor resolution. | | 0.25 | | $^{\circ}\text{C}$ | 1 |

1. Stated temperature accuracy is valid in the range 0 to 60°C. Temperature accuracy outside the 0 to 60°C range is $\pm 8^{\circ}\text{C}$.

Table 52 Temperature sensor

8.16 Random Number Generator (RNG) specifications

| Symbol | Description | Note | Min. | Typ. | Max. | Units | Test level |
|----------------------|------------------------------------|--|------|------|------|---------------|------------|
| I_{RNG} | Run current at 16 MHz. | | | 60 | | μA | 1 |
| $t_{\text{RNG,RAW}}$ | Run time per byte in RAW mode. | Uniform distribution of 0 and 1 is not guaranteed. | | 167 | | μs | 1 |
| $t_{\text{RNG,UNI}}$ | Run time per byte in Uniform mode. | Uniform distribution of 0 and 1 is guaranteed. Time to generate a byte cannot be guaranteed. | | 677 | | μs | 1 |

Table 53 Random Number Generator (RNG) specifications

8.17 AES Electronic Codebook Mode Encryption (ECB) specifications

| Symbol | Description | Min. | Typ. | Max. | Units | Test level |
|-------------------------------|---------------------------------------|------|------|------|---------------|------------|
| I_{ECB} | Run current for ECB. | | 550 | | μA | 1 |
| $t_{\text{START,ECB,ENDECB}}$ | Time for a 16 byte AES block encrypt. | | 8.5 | 17 | μs | 1 |

Table 54 ECB specifications

8.18 AES CCM Mode Encryption (CCM) specifications

| Symbol | Description | Min. | Typ. | Max. | Units | Test level |
|------------------|----------------------|------|------|------|---------------|------------|
| I_{CCM} | Run current for CCM. | | 550 | | μA | 1 |

Table 55 CCM specifications

8.19 Accelerated Address Resolver (AAR) specifications

| Symbol | Description | Min. | Typ. | Max. | Units | Test level |
|-----------------------------|--|------|------|------|---------------|------------|
| I_{AAR} | Run current for AAR. | | 550 | | μA | 1 |
| $t_{\text{START,RESOLVED}}$ | Time for address resolution of 8 IRKs. | | 68 | | μs | 1 |

Table 56 AAR specifications

8.20 Watchdog Timer (WDT) specifications

| Symbol | Description | Min. | Typ. | Max. | Units | Test level |
|------------------|------------------------------------|------------------|------|--------|---------------|------------|
| I_{WDT} | Run current for watchdog timer. | | 0.1 | | μA | 1 |
| t_{WDT} | Time out interval, watchdog timer. | 30 μs | | 36 hrs | | 1 |

Table 57 Watchdog Timer specifications

8.21 Quadrature Decoder (QDEC) specifications

| Symbol | Description | Note | Min. | Typ. | Max. | Units | Test level |
|---------------------|--|---------------------------------|------|------|-------|---------------|------------|
| I_{QDEC} | | | | 12 | | μA | 1 |
| t_{SAMPLE} | Time between sampling signals from quadrature decoder. | | 128 | | 16384 | μs | N/A |
| t_{LED} | Time from LED is turned on to signals are sampled. | Only valid for optical sensors. | 0 | | 511 | μs | N/A |

Table 58 Quadrature Decoder specifications

8.22 Non-Volatile Memory Controller (NVMC) specifications

Flash write is done by executing a program that writes one word (32 bit) consecutively after the other to the flash memory.

The program doing the flash writes could be set up to run from flash or from RAM. The timing of one flash write operation depends on whether the next instructions following the flash write will be fetched from flash or from RAM. Any fetch from flash done before the write operation is finished will give $t_{\text{WRITE,FLASH}}$ timing.

The flash memory is organized in 256 byte rows starting at CODE and UICR start address. Crossing from one row to another will affect the flash write timing when running from RAM.

The time it takes to program the flash memory will depend on different parameters:

- Whether the program doing the flash write is running from RAM or running from flash.
- When running from RAM we will have different timing for:
 - First write operation.
 - Repeated write operations within the same row.
 - Repeated write operation that are crossing from one row to another.

| Symbol | Description | Note | Min. | Typ. | Max. | Units | Test level |
|----------------------------|---|------|------|------|------|---------------|------------|
| t_{ERASEALL} | Erase flash memory. | 1, 2 | | | 20.0 | ms | 1 |
| $t_{\text{PAGEERASEALL}}$ | Erase page in flash memory. | 1, 2 | | | 20.0 | ms | 1 |
| $t_{\text{WRITE,FLASH}}$ | Program running from flash. Write one word to flash memory. | 1, 3 | | | 46.3 | μs | 1 |
| $t_{\text{WRITE,RAM,1st}}$ | Program running from RAM. Write the first word to flash memory. | 1 | | | 40.2 | μs | 1 |
| $t_{\text{WRITE,RAM,2nd}}$ | Program running from RAM. Repeated writes operations following the first, within the same row. | 1 | | | 27.0 | μs | 1 |
| $t_{\text{WRITE,RAM,3rd}}$ | Program running from RAM. Repeated write operation, new word is located on a different row compare to the previous write. | 1 | | | 46.3 | μs | 1 |

1. Max timing is assuming using RC16M, worst case tolerance.
2. The CPU will be halted for the duration of NVMC operations if the CPU tries to fetch data/code from the flash memory.
3. The CPU will be halted for the duration of NVMC operations.

Table 59 NVMC specifications

8.23 General Purpose I/O (GPIO) specifications

| Symbol | Parameter (condition) | Note | Min. | Typ. | Max. | Units |
|----------|---|------|---------|------|---------|------------|
| V_{IH} | Input high voltage. | | 0.7 VDD | | VDD | V |
| V_{IL} | Input low voltage. | | VSS | | 0.3 VDD | V |
| V_{OH} | Output high voltage (std. drive, 0.5 mA). | | VDD-0.3 | | VDD | V |
| V_{OH} | Output high voltage (high-drive, 5 mA). | 1 | VDD-0.3 | | VDD | V |
| V_{OL} | Output low voltage (std. drive, 0.5 mA). | | VSS | | 0.3 | V |
| V_{OL} | Output low voltage (high-drive, 5 mA). | | VSS | | 0.3 | V |
| R_{PU} | Pull-up resistance. | | 11 | 13 | 16 | k Ω |
| R_{PD} | Pull-down resistance. | | 11 | 13 | 16 | k Ω |

1. Maximum number of pins with 5 mA high drive is 3.

Table 60 General Purpose I/O (GPIO) specifications

8.24 Low Power Comparator (LPCOMP) specifications

| Symbol | Description | Min. | Typ. | Max. | Units | Test level |
|---------------------|--|------|------|-----------------|---------|------------|
| I_{LPC} | Run current for LPCOMP. | | 0.5 | | μ A | 1 |
| $t_{LPCANADETOFF}$ | Time from VIN crossing to ANADETECT signal generated when in System OFF. | | | 15 ¹ | μ s | 1 |
| $t_{LPCANADETON}$ | Time from VIN crossing to ANADETECT signal generated when in System ON. | | | 15 ¹ | μ s | 1 |
| $t_{LPCOMPSTARTUP}$ | Startup time for the Low Power Comparator. | | | 40 | μ s | 1 |

1. For 50 mV overdrive

Table 61 Low power comparator specifications

9 Mechanical specifications

9.1 QFN48 package

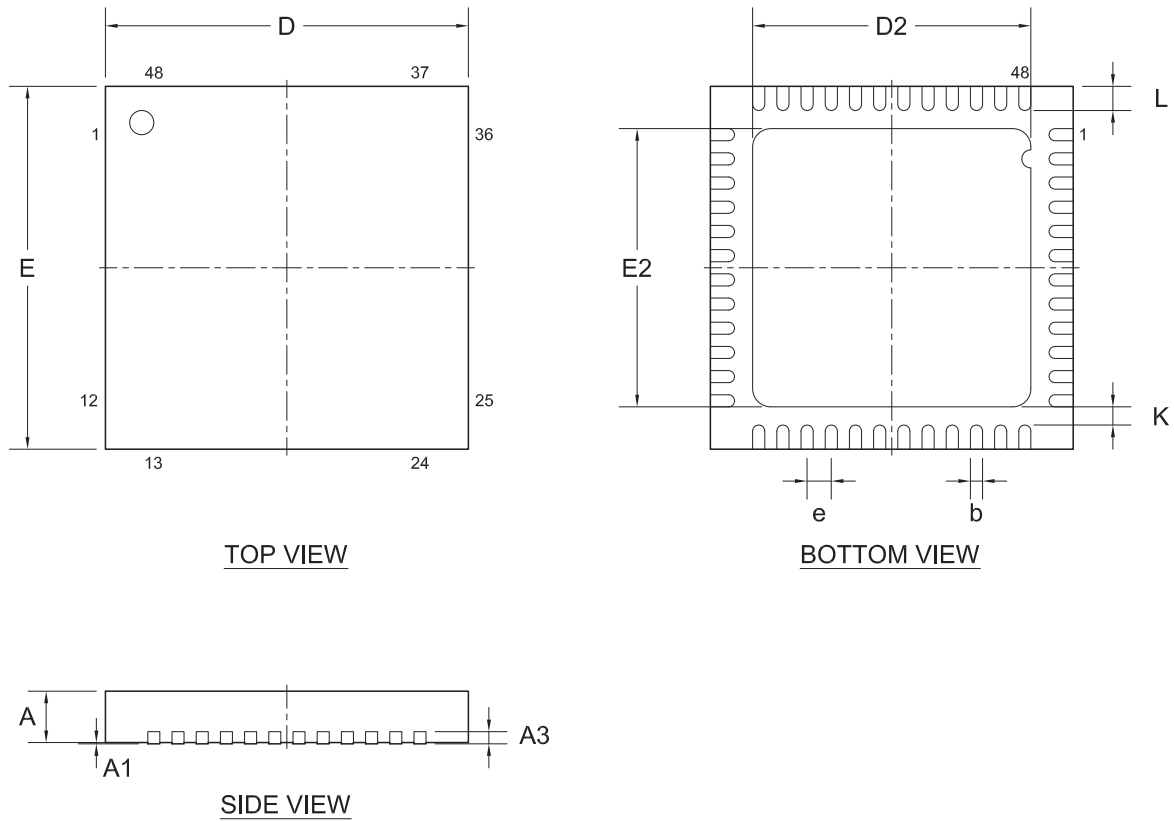

Figure 14 QFN48 6 x 6 mm package

| Package | A | A1 | A3 | b | D, E | D2, E2 | e | K | L | |
|---------------|------|------|------|------|------|--------|------|------|------|-------------|
| QFN48 (6 x 6) | 0.80 | 0.00 | | 0.15 | | 4.50 | | 0.20 | 0.35 | Min. |
| | 0.85 | 0.02 | 0.20 | 0.20 | 6.00 | 4.60 | 0.40 | | 0.40 | Nom. |
| | 0.90 | 0.05 | | 0.25 | | 4.70 | | | 0.45 | Max. |

Table 62 QFN48 dimensions in millimeters

9.2 QFN32 package

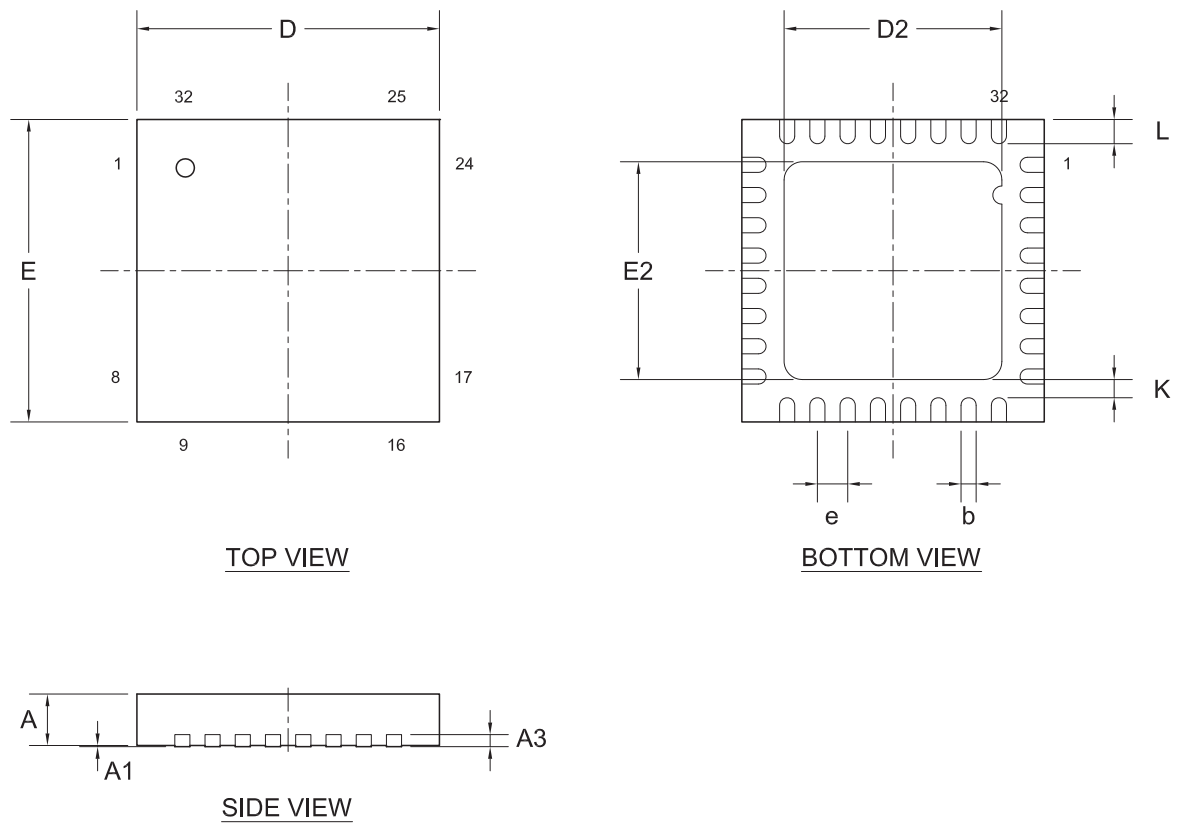

Figure 15 QFN32 5 x 5 mm package

| Package | A | A1 | A3 | b | D, E | D2, E2 | e | K | L | |
|---------------|------|------|------|------|------|--------|------|------|------|-------------|
| QFN32 (5 x 5) | 0.80 | 0.00 | | 0.18 | | 3.50 | | 0.20 | 0.35 | Min. |
| | 0.85 | 0.02 | 0.20 | 0.25 | 5.00 | 3.60 | 0.50 | | 0.40 | Nom. |
| | 0.90 | 0.05 | | 0.30 | | 3.70 | | | 0.45 | Max. |

Table 63 QFN32 dimensions in millimeters

10 Ordering information

10.1 Chip marking

| | | | | | |
|-----|----|-----|----|-----|-----|
| N | 5 | 1 | 8 | 0 | 2 |
| <P> | P> | <V> | V> | <H> | <P> |
| <Y> | Y> | <W> | W> | <L> | L> |

Table 64 Package marking

10.2 Inner box label

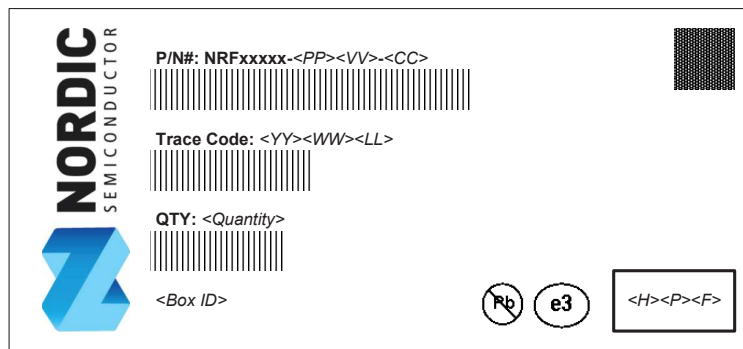

Figure 16 Inner box label

10.3 Outer box label









| | |
|---|---|
|  | |
| FROM: <div style="background-color: #cccccc; width: 100%; height: 60px;"></div> | TO: <div style="background-color: #cccccc; width: 100%; height: 60px;"></div> |
| DEVICE: NRFxxxxx-<PP><VV>-<CC>  <H><P><F> | |
| S/O No.: <Nordic Sales Order>  | |
| CUSTOMER PO No.: <Customer Purchase Order>  | |
| WF LOT No.: <Wafer Lot Number>  | |
| Trace Code: <YY><WW><LL>  | |
| QTY: <Quantity>  | |
| PACKAGE COUNT: <div style="display: flex; align-items: center; gap: 5px;"> <div style="background-color: #cccccc; width: 20px; height: 15px;"></div> of <div style="background-color: #cccccc; width: 20px; height: 15px;"></div> </div> | PACKAGE WEIGHT: <div style="display: flex; align-items: center; gap: 5px;"> <div style="background-color: #cccccc; width: 20px; height: 15px;"></div> KGS  </div> |
| COUNTRY OF ORIGIN: <Country> | |

Figure 17 Outer box label

10.4 Order code

| | | | | | | | | | | | | | | | |
|---|---|---|---|---|---|---|---|---|----|----|----|----|---|----|----|
| n | R | F | 5 | 1 | 8 | 0 | 2 | - | <P | P> | <V | V> | - | <C | C> |
|---|---|---|---|---|---|---|---|---|----|----|----|----|---|----|----|

Table 65 Order code

10.5 Abbreviations

| Abbreviation | Definition and Implemented Codes |
|--------------|---|
| N51/nRF51 | nRF51 series product |
| 802 | Part code |
| <PP> | Package code |
| <VV> | Variant code |
| <H><P><F> | Build code H - Hardware version code P - Production configuration code (production site, etc.) F - Firmware version (Only visible on shipping container label) |
| <YY><WW><LL> | Tracking code YY - Year code WW - Assembly week number LL - Wafer lot code |
| <CC> | Container code |

Table 66 Abbreviations

10.6 Code ranges and values

| <PP> | Package | Size (mm) | Pin/Ball Count | Pitch (mm) |
|------|---------|-----------|----------------|------------|
| QF | QFN | 6 x 6 | 48 | 0.4 |
| QC | QFN | 5 x 5 | 32 | 0.5 |

Table 67 Package codes

| <VV> | Flash (kB) | RAM (kB) | DC/DC Bond-out |
|------|------------|----------|----------------|
| AA | 256 | 16 | YES |

Table 68 Variant codes

| <H> | Description |
|--------|--|
| [A..Z] | Hardware version/revision identifier (incremental) |

Table 69 Hardware version codes

| <P> | Description |
|--------|---|
| [0..9] | Production device identifier (incremental) |
| [A..Z] | Engineering device identifier (incremental) |

Table 70 Production version codes

| <F> | Description |
|--------------|--|
| [A..N, P..Z] | Version of programmed firmware |
| [0] | Delivered without preprogrammed firmware |

Table 71 Firmware version codes

| <YY> | Description |
|----------|-------------------------------|
| [15..99] | Production year: 2015 to 2099 |

Table 72 Year codes

| <WW> | Description |
|---------|--------------------|
| [1..52] | Week of production |

Table 73 Week codes

| <LL> | Description |
|----------|---------------------------------|
| [AA..ZZ] | Wafer production lot identifier |

Table 74 Lot codes

| <CC> | Description |
|------|-------------|
| R7 | 7" Reel |
| R | 13" Reel |
| T | Tray |

Table 75 Container codes

10.7 Product options

10.7.1 nRF ICs

| Order code | MOQ ¹ |
|------------------------------------|------------------|
| nRF51802-QFAA-R7 | 1000 |
| nRF51802-QCAA-R7 | 1500 |
| nRF51802-QFAA-R | 3000 |
| nRF51802-QCAA-R | 4000 |
| nRF51802-QFAA-T nRF51802-QCAA-T | 490 |

1. Minimum Order Quantity.

Table 76 Order code

10.7.2 Development tools

| Order code | Description |
|---------------------------|--|
| nRF51-DK ¹ | nRF51 <i>Bluetooth</i> Smart/ANT/2.4 GHz RF Development Kit |
| nRF51-Dongle ¹ | nRF51 USB dongle for emulator, sniffer, firmware development |

1. Uses the nRF51422-QFAC version of the chip (capable of running both *Bluetooth* low energy and ANT), which is a superset of the nRF51802.

Table 77 Development tools

11 Reference circuitry

For the following reference layouts, C_pcb1 and C_pcb2, between X1 and XC1/XC2, is estimated to 0.5 pF each.

The exposed center pad of the QFN package must be connected to supply ground for proper device operation.

11.1 PCB guidelines

A well designed PCB is necessary to achieve good RF performance. A poor layout can lead to loss in performance or functionality. A qualified RF layout for the IC and its surrounding components, including matching networks, can be downloaded from the [Infocenter](#).

To ensure optimal performance it is essential that you follow the schematics- and layout references closely. Especially in the case of the antenna matching circuitry (components between device pins ANT1,ANT2, VDD_PA and the antenna), any changes to the layout can change the behavior, resulting in degradation of RF performance or a need to change component values. All the reference circuits are designed for use with a 50 ohm single end antenna.

A PCB with a minimum of two layers, including a ground plane, is recommended for optimal performance. On PCBs with more than two layers, put a keep-out area on the inner layers directly below the antenna matching circuitry (components between device pins **ANT1**, **ANT2**, **VDD_PA**, and the antenna) to reduce the stray capacitances that influence RF performance.

A matching network is needed between the differential RF pins **ANT1** and **ANT2** and the antenna, to match the antenna impedance (normally 50 ohm) to the optimum RF load impedance for the chip. For optimum performance, the impedance for the matching network should be set as described in **Section 8.5.7 "Antenna matching network requirements"** on page 50 along with the recommended reference circuitry from **Section 11.3 "QFAA QFN48 package"** on page 73 or **Section 11.4 "QCAA QFN32 package"**.

The DC supply voltage should be decoupled as close as possible to the VDD pins with high performance RF capacitors. See the schematics for recommended decoupling capacitor values. The supply voltage for the chip should be filtered and routed separately from the supply voltages of any digital circuitry.

Long power supply lines on the PCB should be avoided. All device grounds, VDD connections, and VDD bypass capacitors must be connected as close as possible to the IC. For a PCB with a topside RF ground plane, the VSS pins should be connected directly to the ground plane. For a PCB with a bottom ground plane, the best technique is to have via holes as close as possible to the VSS pads. A minimum of one via hole should be used for each VSS pin.

Full-swing digital data or control signals should not be routed close to the crystal or the power supply lines. Capacitive loading of full-swing digital output lines should be minimized in order to avoid radio interference.

11.1.1 PCB layout example

The PCB layout shown in *Figure 18* is a reference layout for the QFN48 package with internal LDO setup. For all available reference layouts, see the [Reference Layout](#) section in our Infocenter.

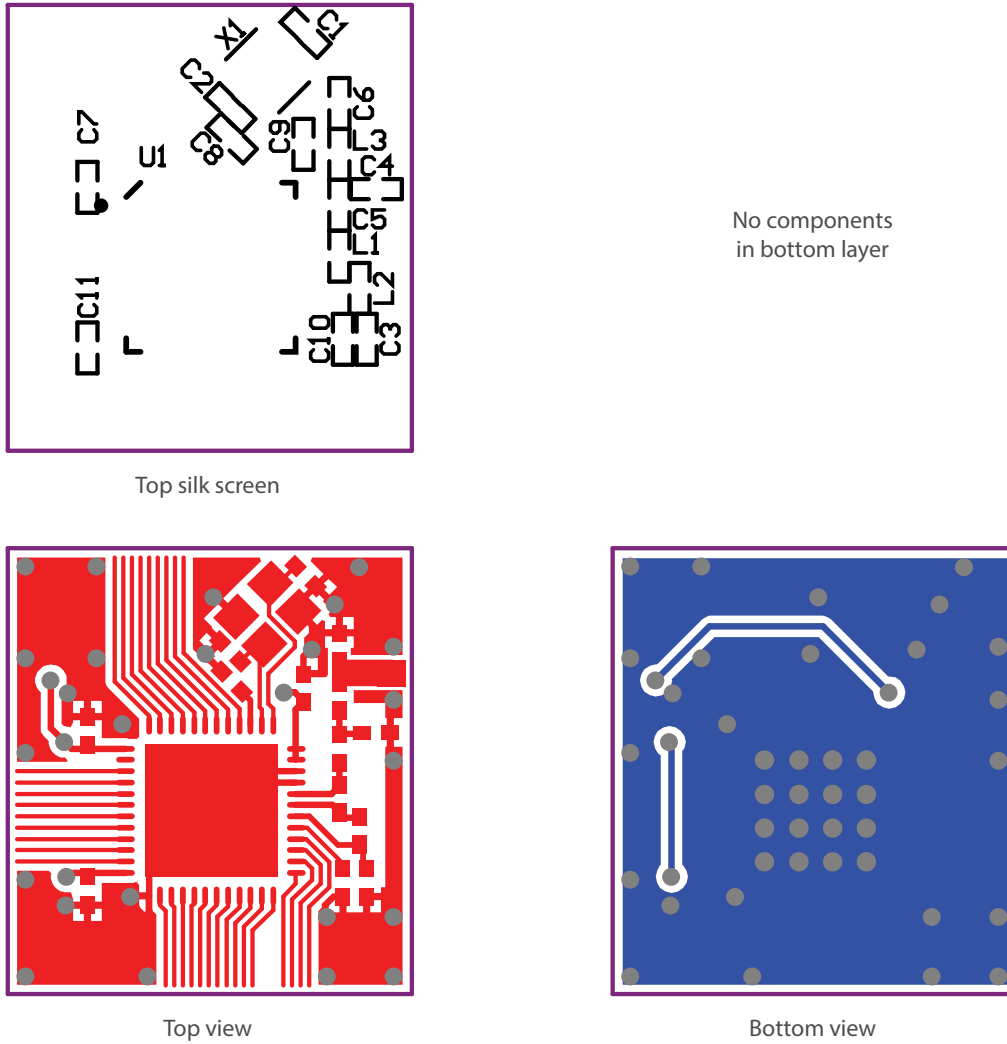

Figure 18 PCB layout example for QFN48 package with internal LDO setup

11.2 Reference design schematics

The following sections covers the reference design schematics for all chip variants of the nRF51802. **Table 78** lists the cross references to the package sections describing each package variant.

| For package | See section: |
|-------------|---|
| QFAA | <i>Section 11.3 "QFAA QFN48 package"</i> on page 73 |
| QCAA | <i>Section 11.4 "QCAA QFN32 package"</i> on page 79 |

Table 78 Cross references to the reference design variants

11.3 QFAA QFN48 package

Documentation for the QFAA QFN48 package reference circuit, including Altium Designer files, PCB layout files, and PCB production files can be downloaded from the [Reference Layout](#) section in our Infocenter.

11.3.1 QFAA QFN48 schematic with internal LDO setup

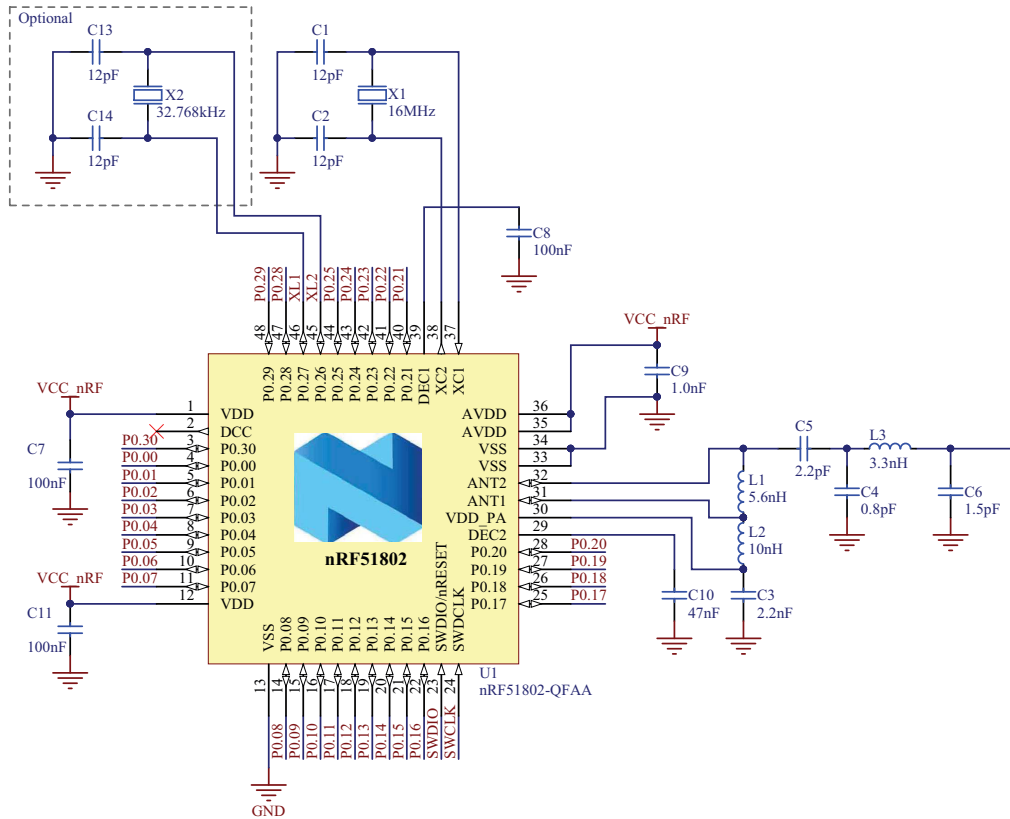

Figure 19 QFAA QFN48 with internal LDO setup

Note: For PCB reference layouts, see the [Reference Layout](#) section in our Infocenter.

11.3.1.1 Bill of Materials

| Designator | Value | Description | Footprint |
|------------------|---------------|--|-----------|
| C1, C2, C13, C14 | 12 pF | Capacitor, NP0, $\pm 2\%$ | 0402 |
| C3 | 2.2 nF | Capacitor, X7R, $\pm 10\%$ | 0402 |
| C4 | 0.8 pF | Capacitor, NP0, $\pm 5\%$ | 0402 |
| C5 | 2.2 pF | Capacitor, NP0, ± 0.1 pF | 0402 |
| C6 | 1.5 pF | Capacitor, NP0, ± 0.1 pF | 0402 |
| C7, C8, C11 | 100 nF | Capacitor, X7R, $\pm 10\%$ | 0402 |
| C9 | 1.0 nF | Capacitor, X7R, $\pm 10\%$ | 0402 |
| C10 | 47 nF | Capacitor, X7R, $\pm 10\%$ | 0402 |
| L1 | 5.6 nH | High frequency chip inductor $\pm 5\%$ | 0402 |
| L2 | 10 nH | High frequency chip inductor $\pm 5\%$ | 0402 |
| L3 | 3.3 nH | High frequency chip inductor $\pm 5\%$ | 0402 |
| U1 | nRF51802-QFAA | RF SoC | QFN-48 |
| X1 | 16 MHz | Crystal SMD 2520, 16 MHz, 8 pF, ± 40 ppm | SMD 2520 |
| X2 | 32.768 kHz | Crystal SMD 3215, 32.768 kHz, 9 pF, ± 20 ppm | SMD 3215 |

Table 79 QFAA QFN48 with internal LDO setup

11.3.2 QFAA QFN48 schematic with low voltage mode setup

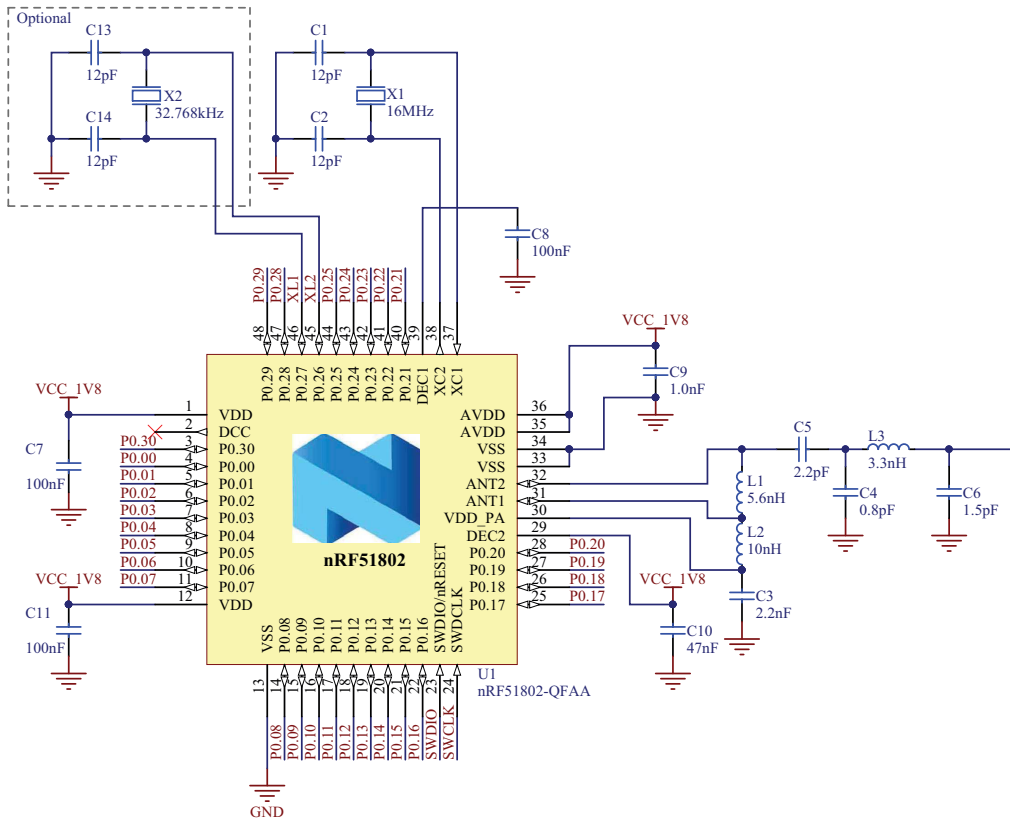

Figure 20 QFAA QFN48 with low voltage mode setup

Note: For PCB reference layouts, see the [Reference Layout](#) section in our Infocenter.

11.3.2.1 Bill of Materials

| Designator | Value | Description | Footprint |
|------------------|---------------|--|-----------|
| C1, C2, C13, C14 | 12 pF | Capacitor, NP0, $\pm 2\%$ | 0402 |
| C3 | 2.2 nF | Capacitor, X7R, $\pm 10\%$ | 0402 |
| C4 | 0.8 pF | Capacitor, NP0, $\pm 5\%$ | 0402 |
| C5 | 2.2 pF | Capacitor, NP0, ± 0.1 pF | 0402 |
| C6 | 1.5 pF | Capacitor, NP0, ± 0.1 pF | 0402 |
| C7, C8, C11 | 100 nF | Capacitor, X7R, $\pm 10\%$ | 0402 |
| C9 | 1.0 nF | Capacitor, X7R, $\pm 10\%$ | 0402 |
| C10 | 47 nF | Capacitor, X7R, $\pm 10\%$ | 0402 |
| L1 | 5.6 nH | High frequency chip inductor $\pm 5\%$ | 0402 |
| L2 | 10 nH | High frequency chip inductor $\pm 5\%$ | 0402 |
| L3 | 3.3 nH | High frequency chip inductor $\pm 5\%$ | 0402 |
| U1 | nRF51802-QFAA | RF SoC | QFN-48 |
| X1 | 16 MHz | Crystal SMD 2520, 16 MHz, 8 pF, ± 40 ppm | SMD 2520 |
| X2 | 32.768 kHz | Crystal SMD 3215, 32.768 kHz, 9 pF, ± 20 ppm | SMD 3215 |

Table 80 QFAA QFN48 with low voltage mode setup

11.3.3 QFAA QFN48 schematic with DC/DC converter setup

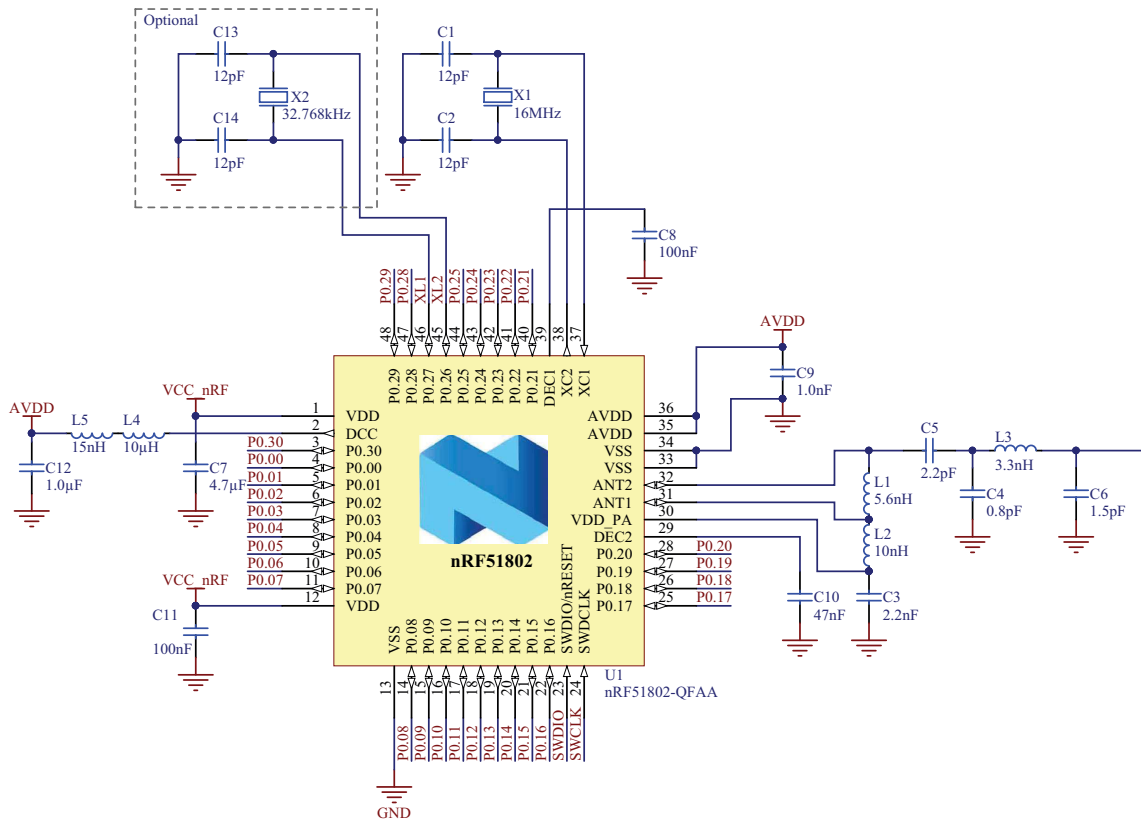

Figure 21 QFAA QFN48 with DC/DC converter setup

Note: For PCB reference layouts, see the [Reference Layout](#) section in our Infocenter.

11.3.3.1 Bill of Materials

| Designator | Value | Description | Footprint |
|------------------|---------------|--|-----------|
| C1, C2, C13, C14 | 12 pF | Capacitor, NP0, $\pm 2\%$ | 0402 |
| C3 | 2.2 nF | Capacitor, X7R, $\pm 10\%$ | 0402 |
| C4 | 0.8 pF | Capacitor, NP0, $\pm 5\%$ | 0402 |
| C5 | 2.2 pF | Capacitor, NP0, ± 0.1 pF | 0402 |
| C6 | 1.5 pF | Capacitor, NP0, ± 0.1 pF | 0402 |
| C7 | 4.7 μ F | Capacitor, X5R, $\pm 10\%$ | 0603 |
| C8, C11 | 100 nF | Capacitor, X7R, $\pm 10\%$ | 0402 |
| C9 | 1.0 nF | Capacitor, X7R, $\pm 10\%$ | 0402 |
| C10 | 47 nF | Capacitor, X7R, $\pm 10\%$ | 0402 |
| C12 | 1.0 μ F | Capacitor, X7R, $\pm 10\%$ | 0603 |
| L1 | 5.6 nH | High frequency chip inductor $\pm 5\%$ | 0402 |
| L2 | 10 nH | High frequency chip inductor $\pm 5\%$ | 0402 |
| L3 | 3.3 nH | High frequency chip inductor $\pm 5\%$ | 0402 |
| L4 | 10 μ H | Chip inductor, $I_{DC,min} = 50$ mA, $\pm 20\%$ | 0603 |
| L5 | 15 nH | High frequency chip inductor $\pm 10\%$ | 0402 |
| U1 | nRF51802-QFAA | RF SoC | QFN-48 |
| X1 | 16 MHz | Crystal SMD 2520, 16 MHz, 8 pF, ± 40 ppm | SMD 2520 |
| X2 | 32.768 kHz | Crystal SMD 3215, 32.768 kHz, 9 pF, ± 20 ppm | SMD 3215 |

Table 81 QFAA QFN48 with DC/DC converter setup

11.4 QCAA QFN32 package

Documentation for the QCAA QFN32 package reference circuit, including Altium Designer files, PCB layout files, and PCB production files can be downloaded from the [Reference Layout](#) section in our Infocenter.

11.4.1 QCAA QFN32 schematic with internal LDO setup

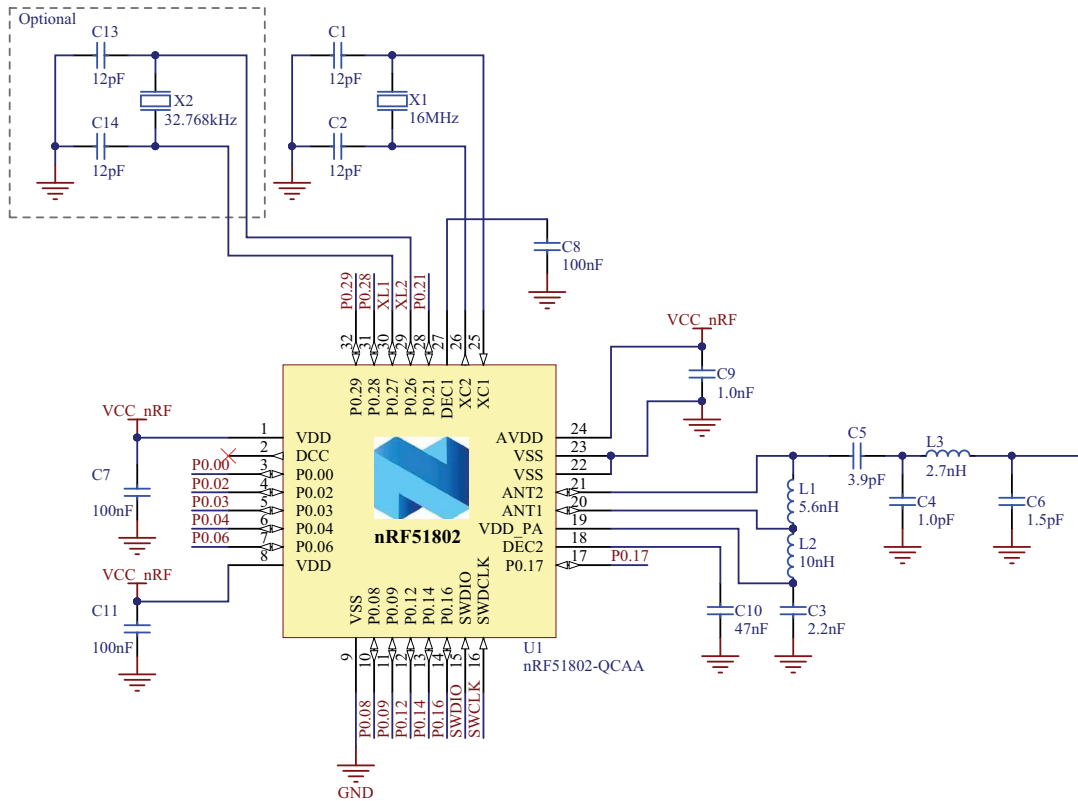

Figure 22 QCAA QFN32 with internal LDO setup

Note: For PCB reference layouts, see the [Reference Layout](#) section in our Infocenter.

11.4.1.1 Bill of Materials

| Designator | Value | Description | Footprint |
|------------------|---------------|--|-----------|
| C1, C2, C13, C14 | 12 pF | Capacitor, NP0, $\pm 2\%$ | 0402 |
| C3 | 2.2 nF | Capacitor, X7R, $\pm 10\%$ | 0402 |
| C4 | 1.0 pF | Capacitor, NP0, ± 0.1 pF | 0402 |
| C5 | 3.9 pF | Capacitor, NP0, ± 0.1 pF | 0402 |
| C6 | 1.5 pF | Capacitor, NP0, ± 0.1 pF | 0402 |
| C7, C8, C11 | 100 nF | Capacitor, X7R, $\pm 10\%$ | 0402 |
| C9 | 1.0 nF | Capacitor, X7R, $\pm 10\%$ | 0402 |
| C10 | 47 nF | Capacitor, X7R, $\pm 10\%$ | 0402 |
| L1 | 5.6 nH | High frequency chip inductor $\pm 5\%$ | 0402 |
| L2 | 10 nH | High frequency chip inductor $\pm 5\%$ | 0402 |
| L3 | 2.7 nH | High frequency chip inductor $\pm 5\%$ | 0402 |
| U1 | nRF51802-QCAA | RF SoC | QFN-32 |
| X1 | 16 MHz | Crystal SMD 2520, 16 MHz, 8 pF, ± 40 ppm | SMD 2520 |
| X2 | 32.768 kHz | Crystal SMD 3215, 32.768 kHz, 9 pF, ± 20 ppm | SMD 3215 |

Table 82 QCAA QFN32 with internal LDO setup

11.4.2 QCAA QFN32 schematic with low voltage mode setup

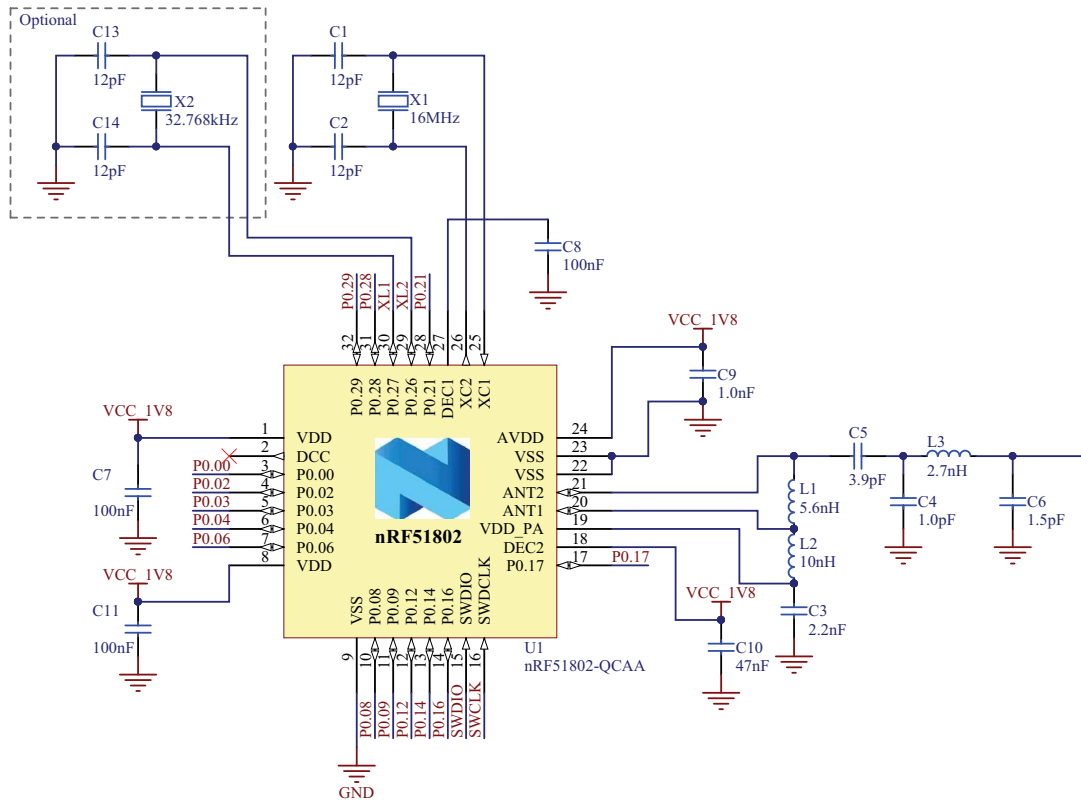

Figure 23 QCAA QFN32 with low voltage mode setup

Note: For PCB reference layouts, see the [Reference Layout](#) section in our Infocenter.

11.4.2.1 Bill of Materials

| Designator | Value | Description | Footprint |
|------------------|---------------|--|-----------|
| C1, C2, C13, C14 | 12 pF | Capacitor, NP0, $\pm 2\%$ | 0402 |
| C3 | 2.2 nF | Capacitor, X7R, $\pm 10\%$ | 0402 |
| C4 | 1.0 pF | Capacitor, NP0, ± 0.1 pF | 0402 |
| C5 | 3.9 pF | Capacitor, NP0, ± 0.1 pF | 0402 |
| C6 | 1.5 pF | Capacitor, NP0, ± 0.1 pF | 0402 |
| C7, C8, C11 | 100 nF | Capacitor, X7R, $\pm 10\%$ | 0402 |
| C9 | 1.0 nF | Capacitor, X7R, $\pm 10\%$ | 0402 |
| C10 | 47 nF | Capacitor, X7R, $\pm 10\%$ | 0402 |
| L1 | 5.6 nH | High frequency chip inductor $\pm 5\%$ | 0402 |
| L2 | 10 nH | High frequency chip inductor $\pm 5\%$ | 0402 |
| L3 | 2.7 nH | High frequency chip inductor $\pm 5\%$ | 0402 |
| U1 | nRF51802-QCAA | RF SoC | QFN-32 |
| X1 | 16 MHz | Crystal SMD 2520, 16 MHz, 8 pF, ± 40 ppm | SMD 2520 |
| X2 | 32.768 kHz | Crystal SMD 3215, 32.768 kHz, 9 pF, ± 20 ppm | SMD 3215 |

Table 83 QCAA QFN32 with low voltage mode setup

11.4.3 QCAA QFN32 schematic with DC/DC converter setup

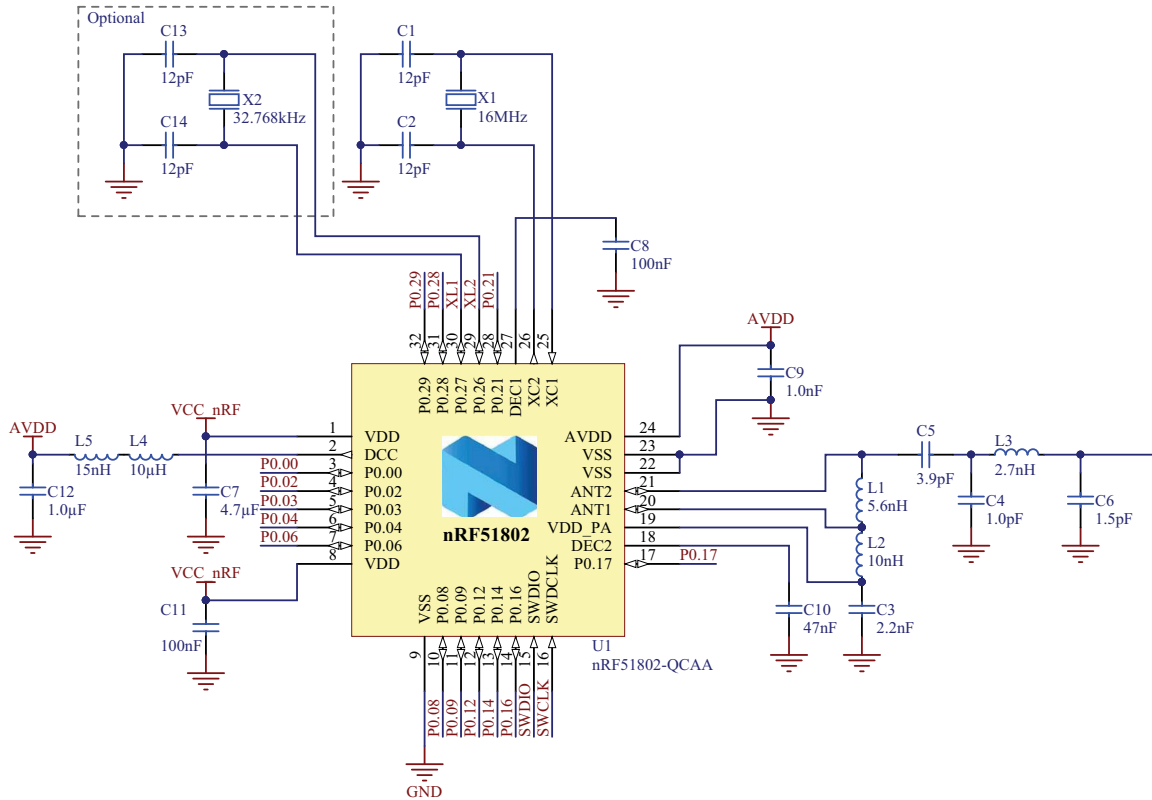

Figure 24 QCAA QFN32 with DC/DC converter setup

Note: For PCB reference layouts, see the [Reference Layout](#) section in our Infocenter.

11.4.3.1 Bill of Materials

| Designator | Value | Description | Footprint |
|------------------|---------------|--|-----------|
| C1, C2, C13, C14 | 12 pF | Capacitor, NP0, $\pm 2\%$ | 0402 |
| C3 | 2.2 nF | Capacitor, X7R, $\pm 10\%$ | 0402 |
| C4 | 1.0 pF | Capacitor, NP0, ± 0.1 pF | 0402 |
| C5 | 3.9 pF | Capacitor, NP0, ± 0.1 pF | 0402 |
| C6 | 1.5 pF | Capacitor, NP0, ± 0.1 pF | 0402 |
| C7 | 4.7 μ F | Capacitor, X5R, $\pm 10\%$ | 0603 |
| C8, C11 | 100 nF | Capacitor, X7R, $\pm 10\%$ | 0402 |
| C9 | 1.0 nF | Capacitor, X7R, $\pm 10\%$ | 0402 |
| C10 | 47 nF | Capacitor, X7R, $\pm 10\%$ | 0402 |
| C12 | 1.0 μ F | Capacitor, X7R, $\pm 10\%$ | 0603 |
| L1 | 5.6 nH | High frequency chip inductor $\pm 5\%$ | 0402 |
| L2 | 10 nH | High frequency chip inductor $\pm 5\%$ | 0402 |
| L3 | 2.7 nH | High frequency chip inductor $\pm 5\%$ | 0402 |
| L4 | 10 μ H | Chip inductor, $I_{DC,min} = 50$ mA, $\pm 20\%$ | 0603 |
| L5 | 15 nH | High frequency chip inductor $\pm 10\%$ | 0402 |
| U1 | nRF51802-QCAA | RF SoC | QFN-32 |
| X1 | 16 MHz | Crystal SMD 2520, 16 MHz, 8 pF, ± 40 ppm | SMD 2520 |
| X2 | 32.768 kHz | Crystal SMD 3215, 32.768 kHz, 9 pF, ± 20 ppm | SMD 3215 |

Table 84 QCAA QFN32 with DC/DC converter setup

12 Glossary

| Term | Description |
|------|---|
| EOC | Extreme Operating Conditions |
| GFSK | Gaussian Frequency-Shift Keying |
| GPIO | General Purpose Input Output |
| ISM | Industrial Scientific Medical |
| MOQ | Minimum Order Quantity |
| NOC | Nominal Operating Conditions |
| NVMC | Non-Volatile Memory Controller |
| QDEC | Quadrature Decoder |
| RF | Radio Frequency |
| RoHS | Restriction of Hazardous Substances |
| RSSI | Radio Signal Strength Indicator |
| SPI | Serial Peripheral Interface |
| TWI | Two-Wire Interface |
| UART | Universal Asynchronous Receiver Transmitter |

Table 85 Glossary